

*lamps by Venetia Studium*

# FORTEVNY



## MARIANO FORTUNY

(Granada 1871 - Venezia 1949)

Artista, fotografo, designer... è difficile individuare quale aspetto della personalità e dell'opera di Mariano Fortuny fosse prevalente. L'intera sua produzione artistica si fonda su una straordinaria sintesi di epoche, stili e tecniche, che solo a Venezia, crogiolo di civiltà, potevano tradursi nella creazione di oggetti di alto valore estetico. Attraverso un percorso filologico che trae ispirazione dalle nobili radici dell'arte d'Occidente e dalla magia dei paesi d'Oriente, Mariano Fortuny diventa tra gli interpreti più originali dell' "età d'argento" veneziana. La costante ricerca sull'illuminazione lo portò a depositare una serie di brevetti, tra cui il dispositivo per il controllo dell'intensità della luce, che verrà adottato dai più prestigiosi teatri del mondo. Curioso e intraprendente si addentrò anche nell'universo della moda femminile: la sua collezione di tuniche in seta plissée, tra cui il famoso "Delphos", evocato anche da Proust nella sua Recherche, divenne un "must" di eleganza per le divine del tempo.

Artist, photographer, designer... it is hard to single out which aspect of the personality and work of Mariano Fortuny was predominant. His entire artistic production was based on an extraordinary synthesis of worlds and eras, of styles and techniques that only in Venice, a melting pot of civilizations, could be transformed into the creation of exquisite products. Through philological experimentation inspired by the noble roots of Western art and the magic of the Orient, Mariano Fortuny became one of the most original interpreters of Venice's "Silver Age". His constant research into lighting led him to file a number of patents, including a device to control light intensity, used in the world's most prestigious theatres. Curious and enterprising, he even penetrated the universe of female fashion. His collection of pleated silk tunics, including the famous "Delphos" evoked by Proust in his Recherche, represented a must in elegance for chic young women of the past.



## THE TWO BRANDS

VENETIA STUDIUM® e FORTUNY® sono due volti di un'unica anima, due marchi che si fondono nel progetto culturale e straordinario che rilancia l'eleganza e il gusto novecentesco nel design delle lampade. Le lampade FORTUNY® sono prodotte in esclusiva dalla Venetia Studium, che ne detiene il marchio a livello mondiale. Ricercatezza, accorgimenti tecnici, qualità delle finiture e cura dei dettagli contraddistinguono l'originalità di ogni lampada che porta impresso il marchio FORTUNY®.

Lino Lando, artefice e fondatore dell'azienda, coltiva l'ambizione di creare oggetti nuovi che parlino il linguaggio antico dell'eleganza e del buon gusto; un sogno che condivide da anni con i figli, Luca e Matteo.

La produzione di lampade FORTUNY® nasce a Venezia e da Venezia assorbe l'atmosfera e i colori; è la città stessa, con i suoi riflessi cangianti che raccoglie l'eredità del maestro e forgia il cromatismo di tutti i prodotti Venetia Studium.

VENETIA STUDIUM® and FORTUNY® are two faces of a single coin, two names coming together in an extraordinary cultural project reviving the elegance of early 20th century tastes in the design of lamps.

FORTUNY® lamps are produced exclusively by Venetia Studium, the only company in the world entitled to use the trademark.

Sophistication, refined techniques, a high quality finish and attention to detail are the distinctive features of each original lamp bearing the FORTUNY® trademark.

The ambition of the company's founder, Lino Lando, is to create new objects speaking an ancient language of elegance and good taste, a dream he shares with his sons Luca and Matteo.

Venice is the birthplace of FORTUNY® lamps and it is Venice which gives them their atmosphere and colours.

It is the city itself with its ever-changing reflections which inherits the legacy of the master and forges the colours of all Venetia Studium products.



## SILK LAMPS

In questa sezione troverete descritte caratteristiche tecniche e versatilità applicativa dei vari modelli delle lampade FORTUNY® in seta.

La seta utilizzata da Venetia Studium è tessuta con filato a fibre lunghissime, di elevata consistenza e spessore, che garantisce alle lampade resistenza e durata nel tempo.

La seta, ineguagliabile filtro di luce, decorata e plasmata su strutture metalliche, trasforma ogni lampada in una vera e propria scultura, elegante, suggestiva... senza tempo.

This section describes the technical characteristics and adaptability of the various models of silk FORTUNY® lamps.

The silk used by Venetia Studium is woven from yarn with very long fibres of a good texture and thickness, making the lamps resistant and long lasting. Decorated and moulded on metal structures, silk, incomparable filter of light, transforms each lamp into a genuine and authentic sculpture, elegant, charming and timeless.



*Scheherazade  
with metal ring*

# FOURTYNINE



Geometric



Herbarium

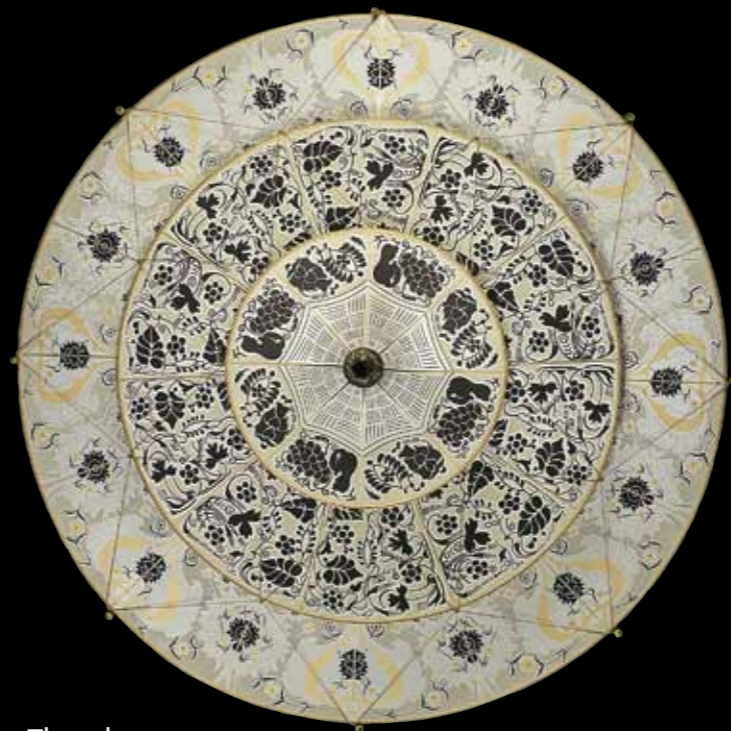

Floral

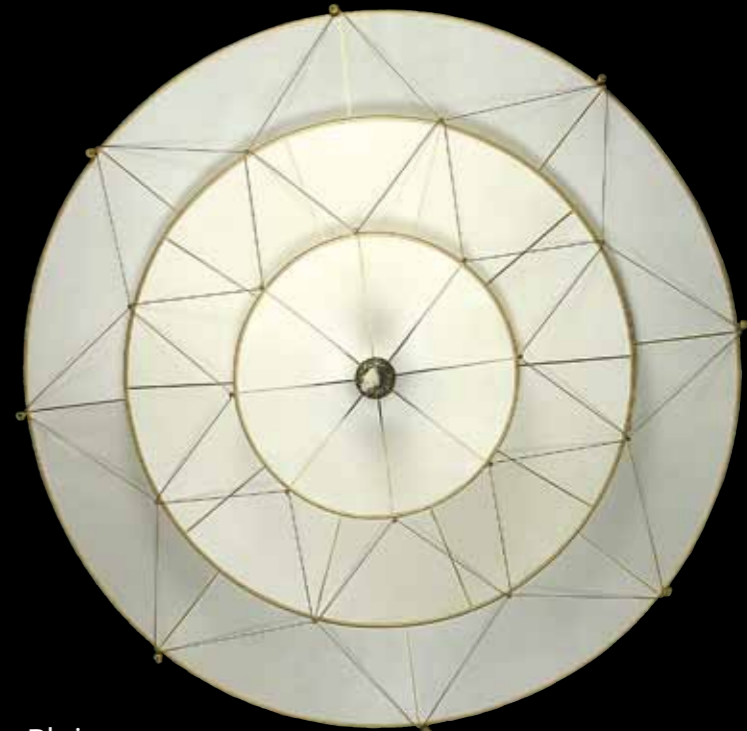

Plain

SCHEHERAZADE  
WITH METAL RING

structure: brass  
burnished metal  
fabric: silk  
murano glass beads  
weight: lb.33  
max 5 x 100 watt

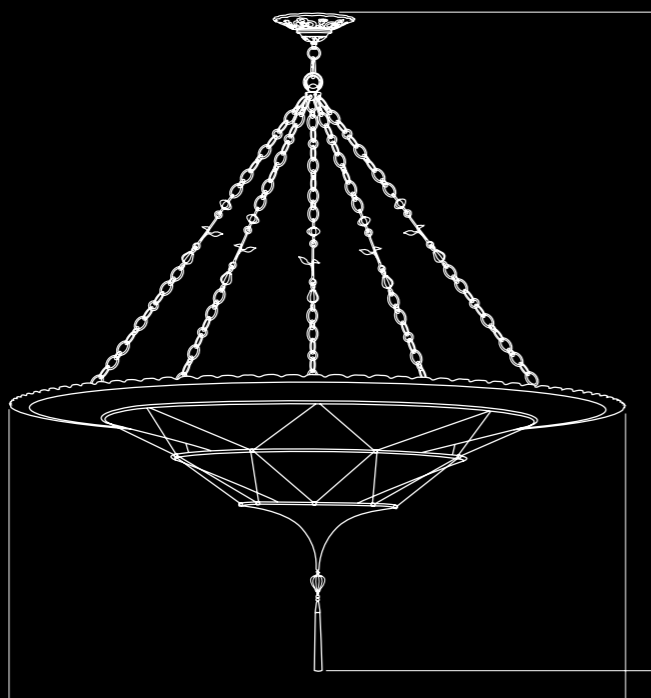

cm 192 - in. 75 5/8

cm 185 - in. 72 7/8

art. 185 SHC

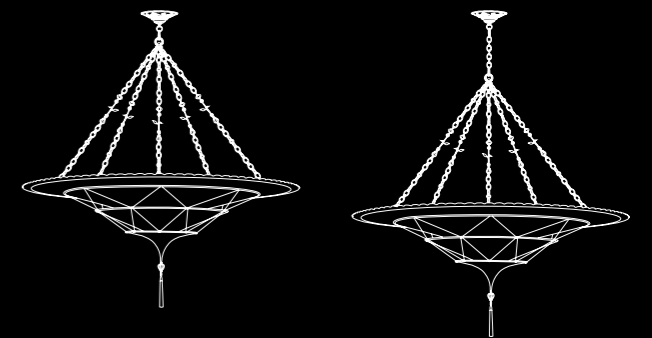



*Scheherazade*

# FOURTYNINE

Bund 18 . Shanghai, China



SCHEHERAZADE

structure: brass  
 fabric: silk  
 murano glass beads  
 weight: 1b.9 oz.11  
 standard 1 x 100 watt  
 optional 4 x 100 watt

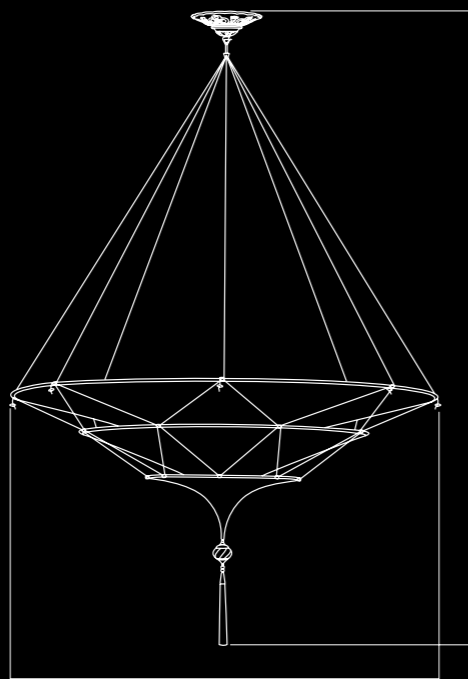

cm 125,5 - in. 49 3/8

art. 126 SH

Given its characteristics and size, Scheherazade is made in silk only. Comparative tests on various materials identified silk as the most appropriate for durability, strength and practicality. Its lightness simplifies and facilitates assembling and maintenance of the lamp.

cm 192 - in. 75 5/8



Geometric



Herbarium



Floral

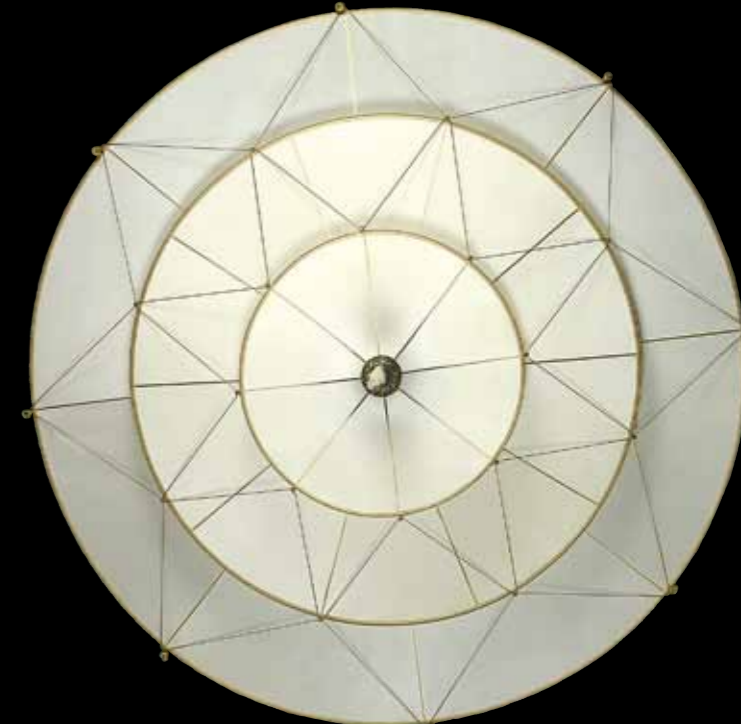

Plain

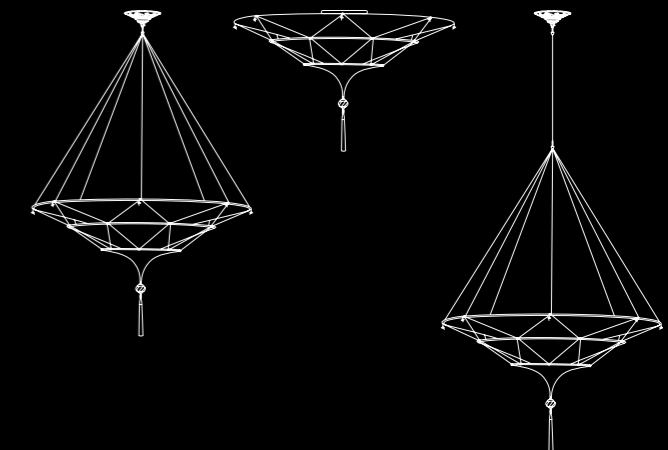





*Scheherazade two tiers  
with metal ring*

# FOORTYNY

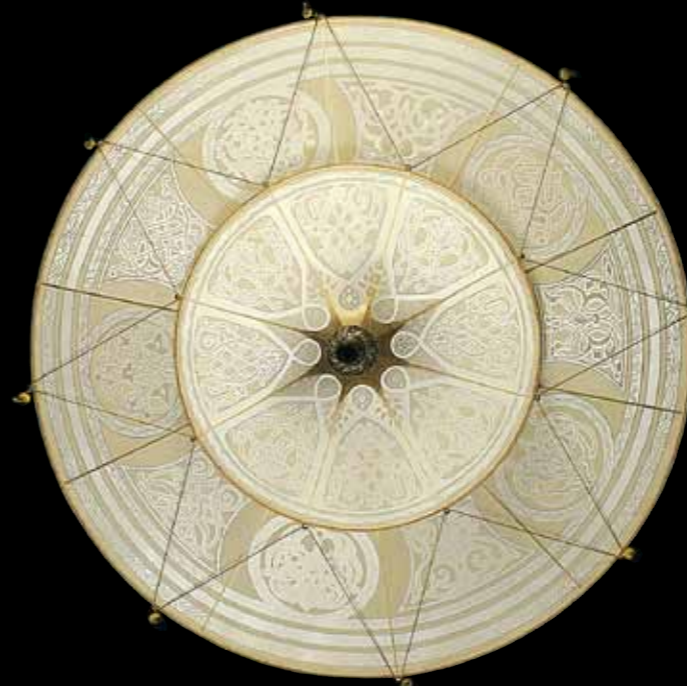

Geometric



Herbarium



Floral

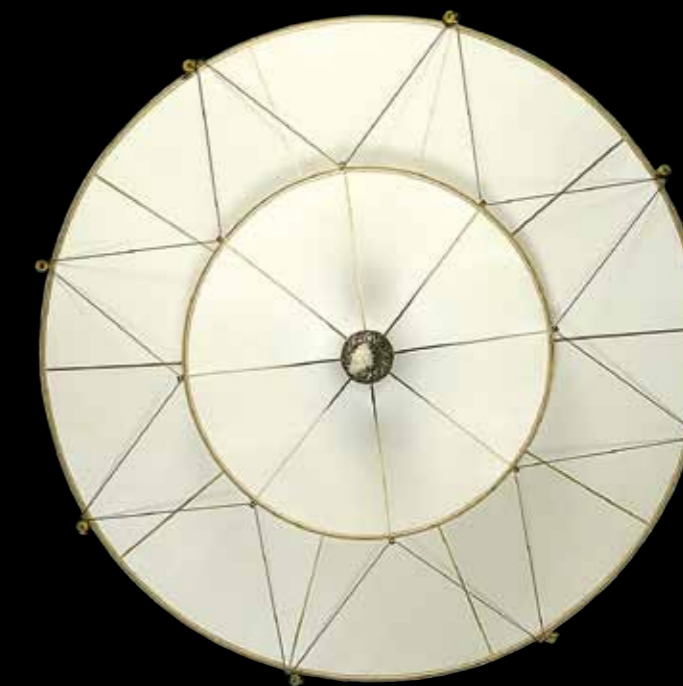

Plain

SCHEHERAZADE  
TWO TIERS  
WITH METAL RING

structure: brass  
burnished metal  
fabric: silk  
murano glass beads  
weight: lb. 15 oz. 7  
standard 1 x 100 watt  
optional 3 x 100 watt

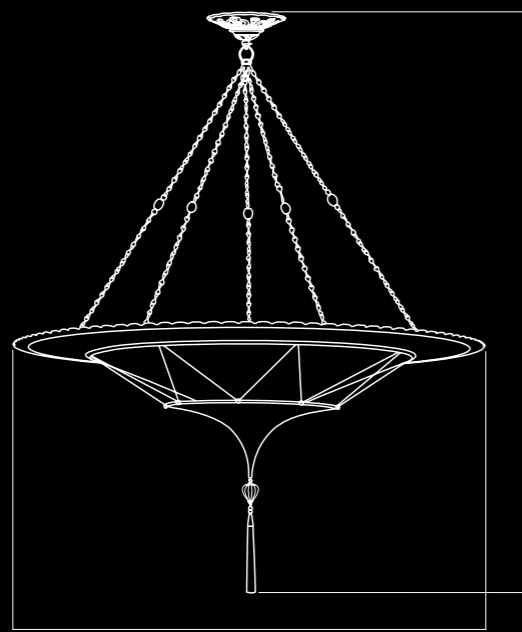

cm 125 - in. 49 1/4

cm 177 - in. 69 5/8

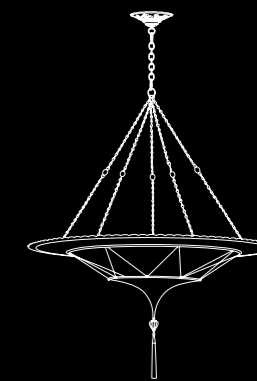
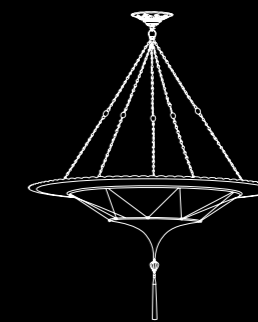

art. 125 SHC



*Scheherazade two tiers*

Gran Hotel La Florida . Barcelona, Spain

# FOURTYVINY



SCHEHERAZADE  
TWO TIERS

structure: brass  
fabric: silk  
murano glass beads  
weight: 1b.3 oz.15  
standard 1 x 100 watt  
optional 3 x 100 watt

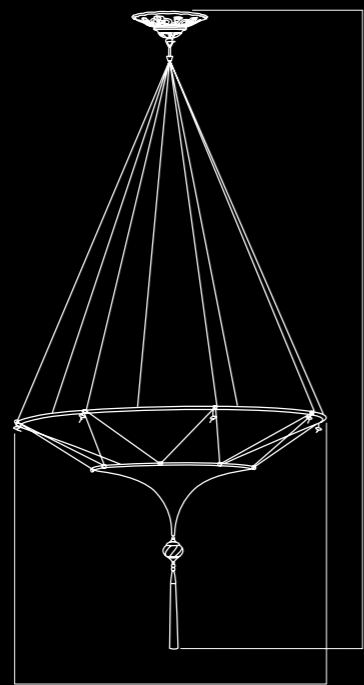

cm 86 - in. 33 7/8

cm 177 - in. 69 5/8

art. 086 SH

Given its characteristics and size, Scheherazade two tiers is made in silk only. Comparative tests on various materials identified silk as the most appropriate for durability, strength and practicality. Its lightness simplifies and facilitates assembling and maintenance of the lamp.

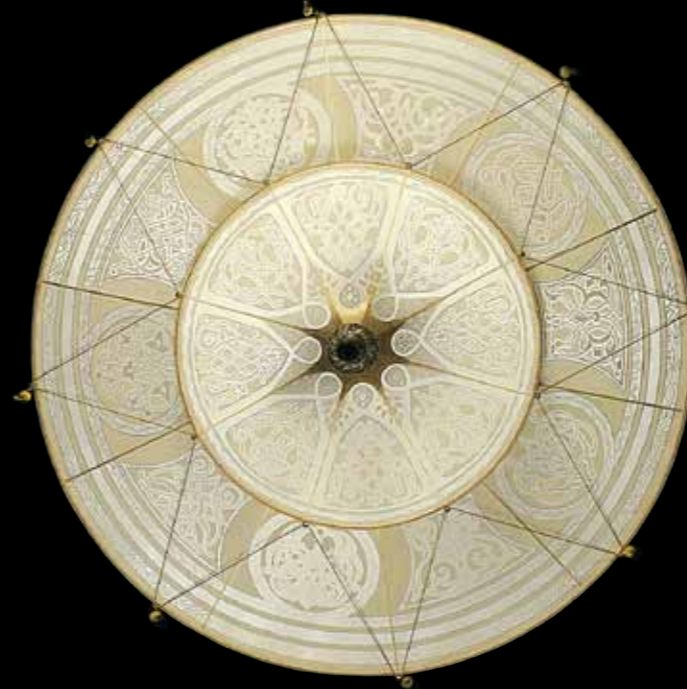

Geometric



Herbarium

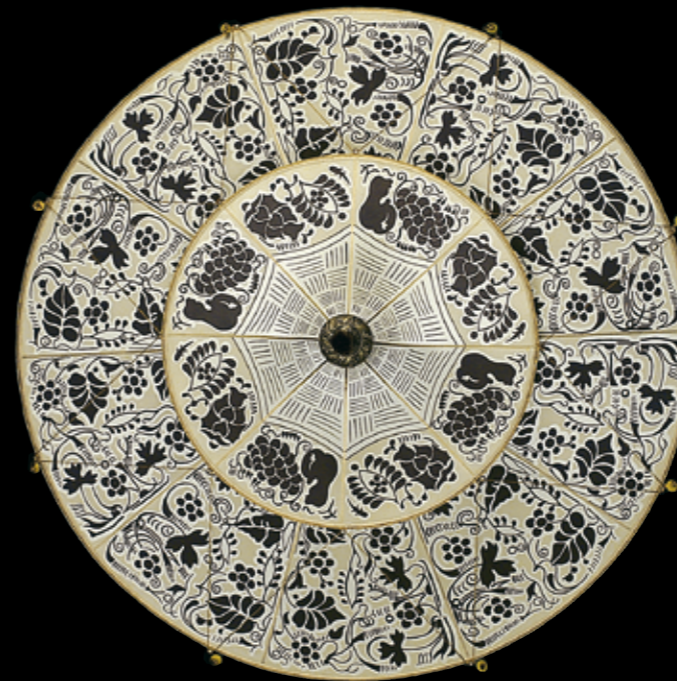

Floral

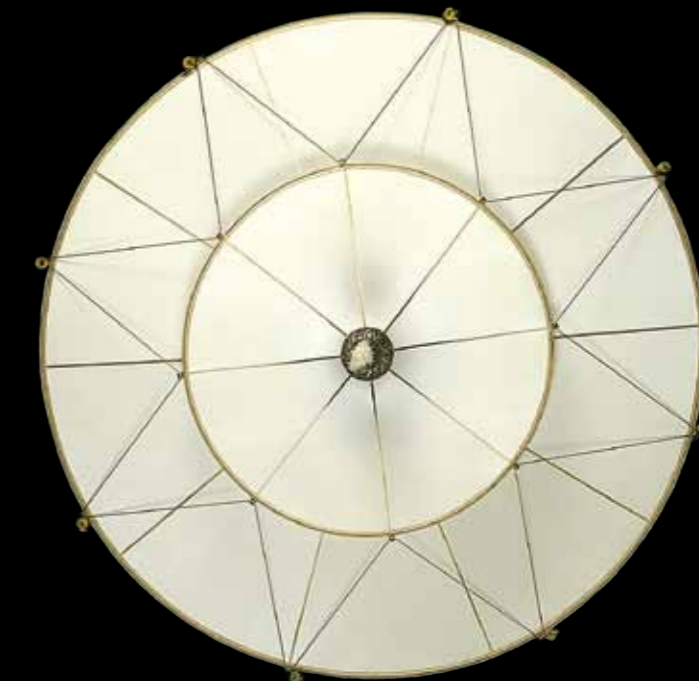

Plain

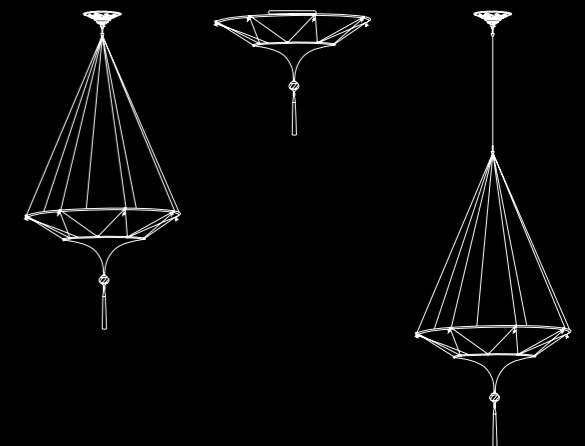



*Scudo Saraceno  
with metal ring*

# FOURTYNRY



Classic



Carduus



Serpentine



Plain

SCUDO  
SARACENO  
WITH METAL RING

structure: brass  
burnished metal  
fabric: silk  
murano glass beads  
60/75 watt

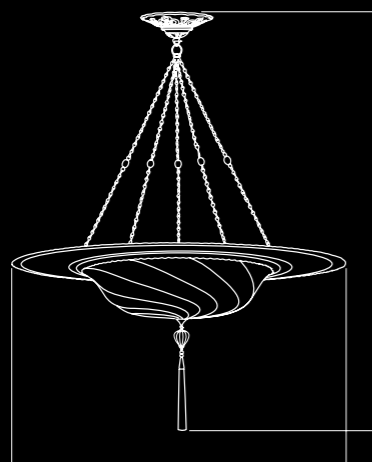

cm 84 - in. 33  
cm 96 - in. 37 3/4

art. X 084 SAC  
art. X 096 SAC

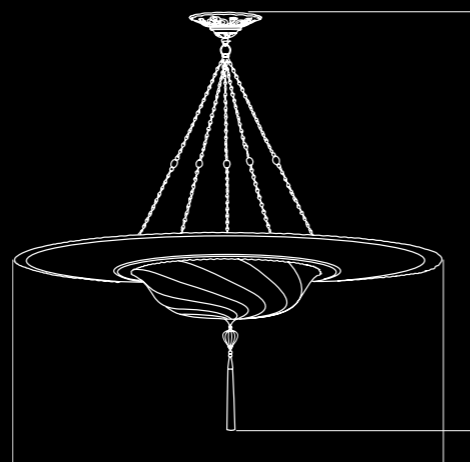

cm 114 - in. 44 7/8  
cm 126 - in. 49 5/8

art. X 114 SAC  
art. X 126 SAC

cm 127 - in. 50  
cm 139,5 - in. 55

cm 127 - in. 50  
cm 139,5 - in. 55

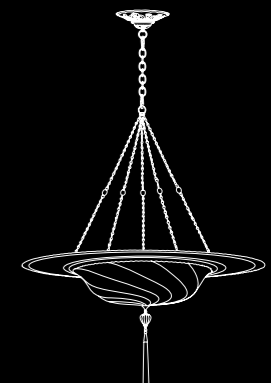
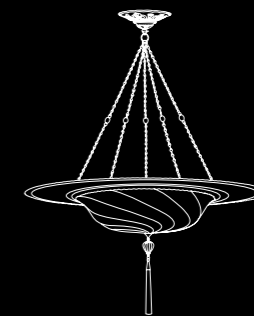



*Scudo Saraceno*

# FORGETVINY



Classic



Carduus



Serpentine



Plain

SCUDO SARACENO

structure: brass  
 fabric: silk  
 murano glass beads  
 weight:  
 lb.1 oz.8 small size  
 lb.2 oz.3 medium size  
 lb.3 oz.10 large size  
 75/100 watt

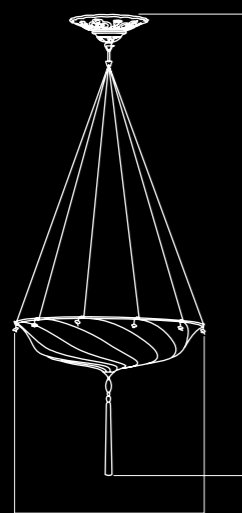

cm 50 - in. 19 3/4

cm 122 - in. 48

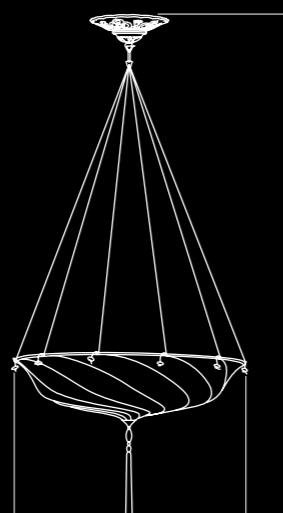

cm 61,5 - in. 24 1/4

cm 134,5 - in. 53

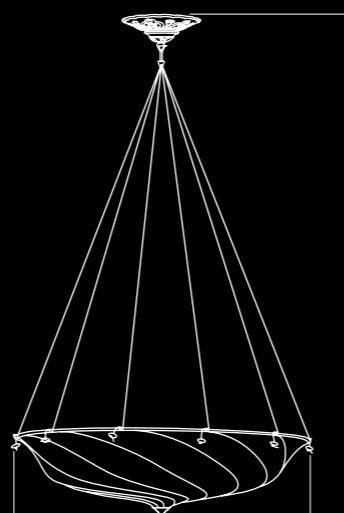

cm 78,5 - in. 30 7/8

cm 158,5 - in. 62 3/8

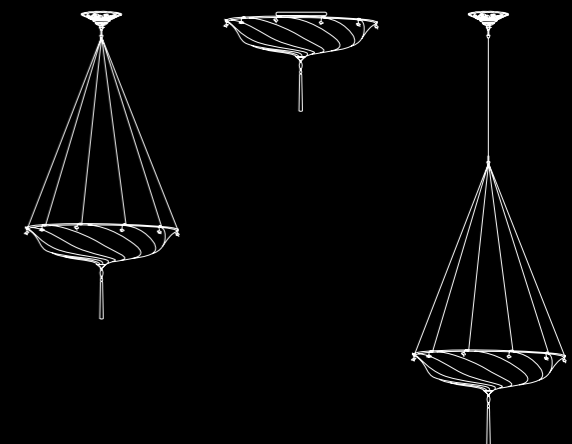

art. 050 SA

art. 062 SA

art. 079 SA





*Samarkanda  
with metal ring*

# FOR TWINNY



Plain



Serpentine

SAMARKANDA  
WITH METAL RING

structure: brass  
burnished metal  
fabric: silk  
murano glass beads  
weight: lb.6 oz.6  
60/75 watt

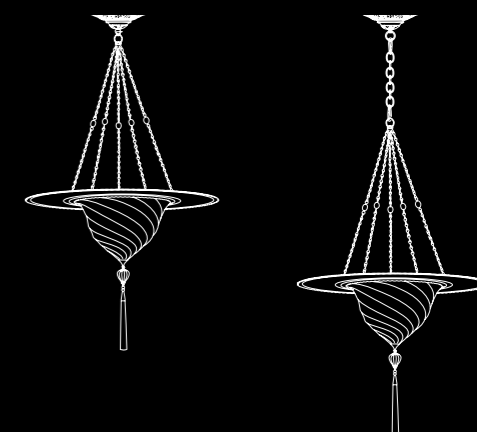
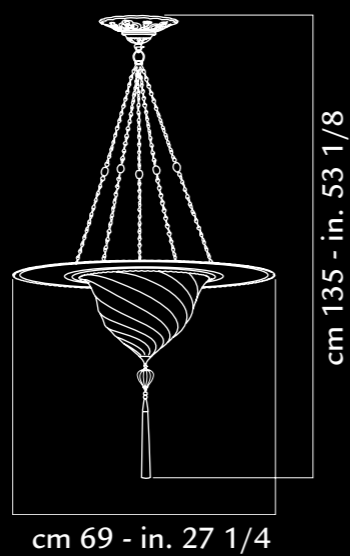

art. X 069 SKC



*Samarkanda with disk  
Samarkanda*

# FOR T V N Y



Decò



Plain

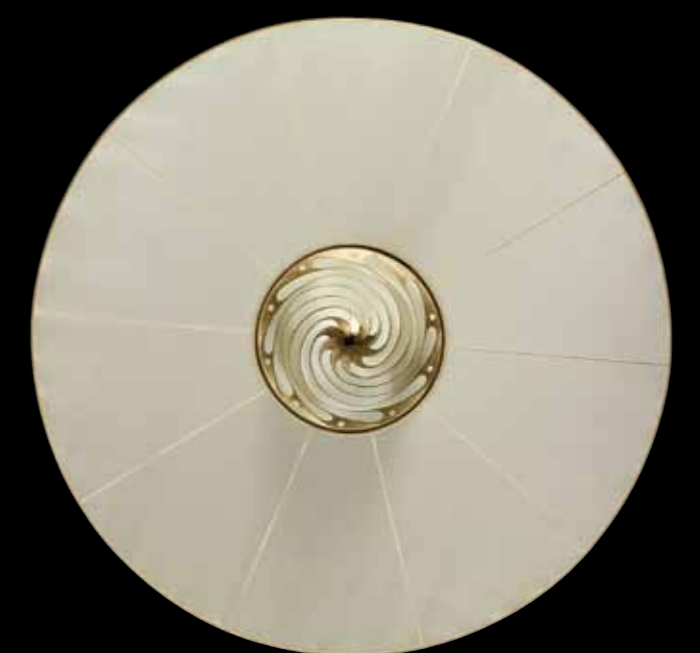

SAMARKANDA  
WITH DISK

structure: brass  
fabric: silk  
murano glass beads  
weight: lb.3 oz.5  
60/75 watt

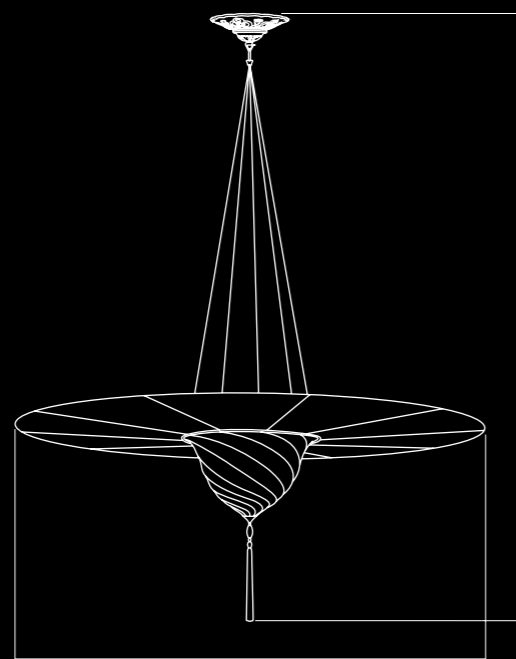

cm 124 - in. 48 7/8

cm 162 - in. 63 3/4

art. 124 SD



Serpentine



Decò



Plain

SAMARKANDA

structure: brass  
 fabric: silk  
 murano glass beads  
 weight: oz. 14  
 60/75 watt

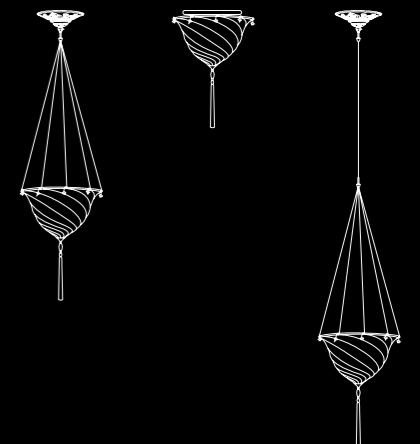
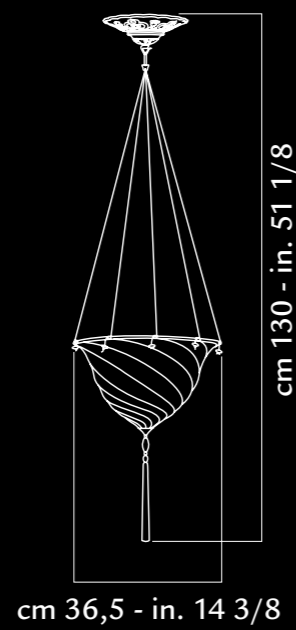

art. 037 SK

# FOURTYNINE

*Cesendello*

Palazzo Stern . Venice, Italy





CESENDELLO

structure: brass  
 fabric: silk  
 murano glass beads  
 max 25 watt

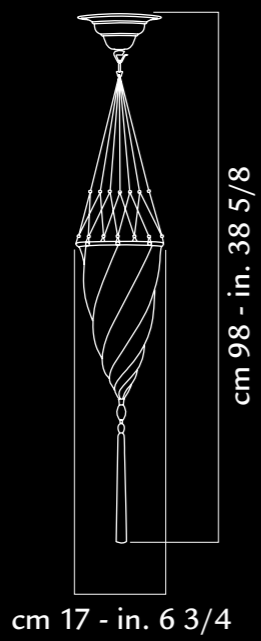

art. 017 CE-1

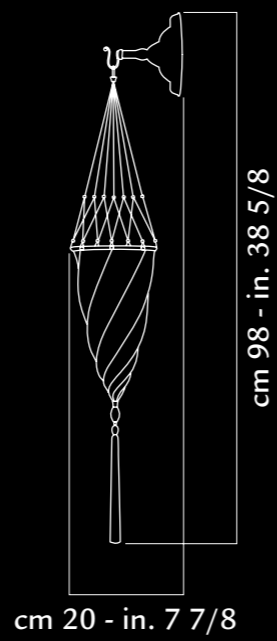

art. 017 CE-2

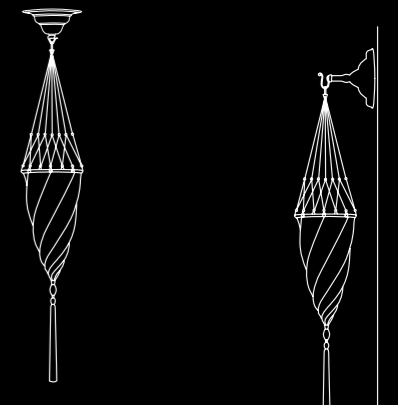

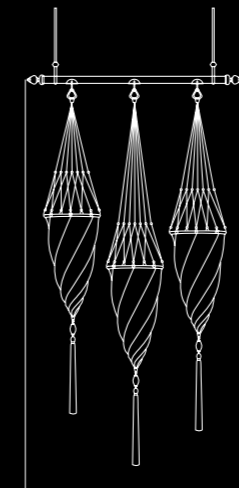
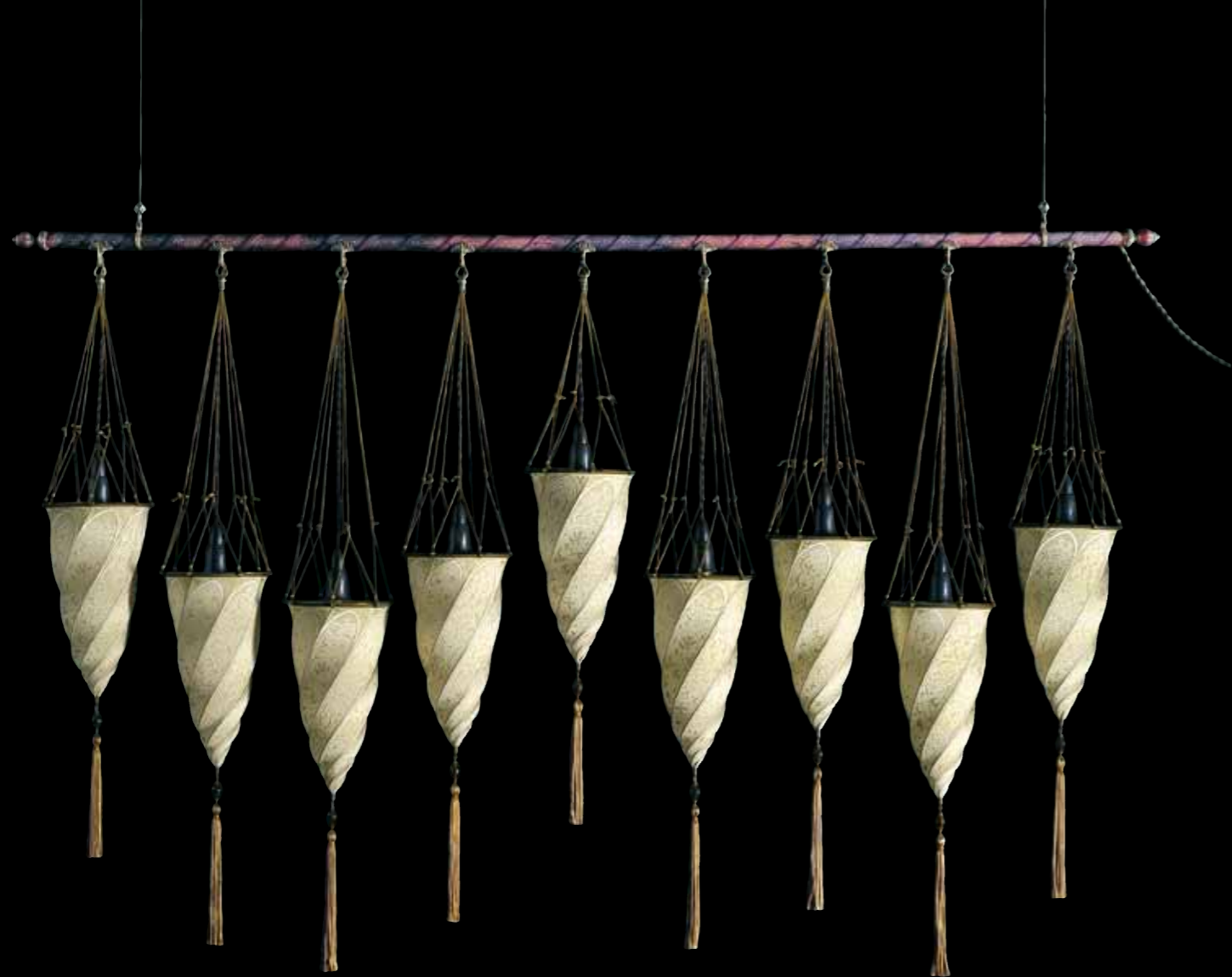

cm 62 - in. 24 3/8

art. AF 017-3

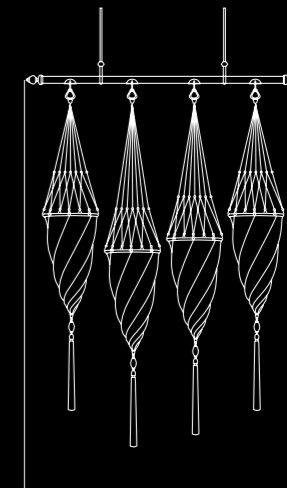

cm 80 - in. 31 1/2

art. AF 017-4

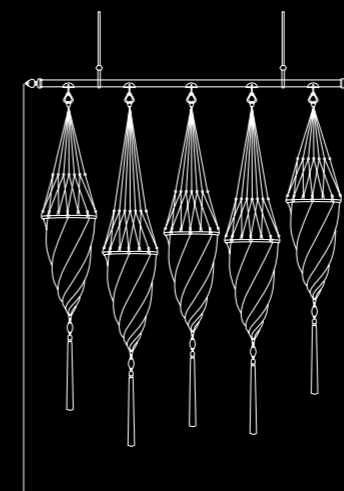

cm 98 - in. 38 5/8

art. AF 017-5

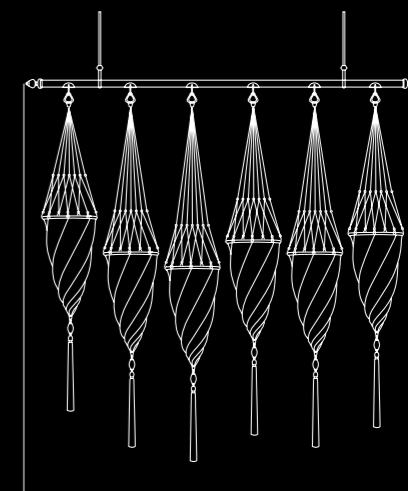

cm 116 - in. 45 2/3

art. AF 017-6

CESENDELLI  
ON A ROD

structure: brass  
fabric: silk  
murano glass beads  
rod covered with fabric  
max 25 watt (x 9)

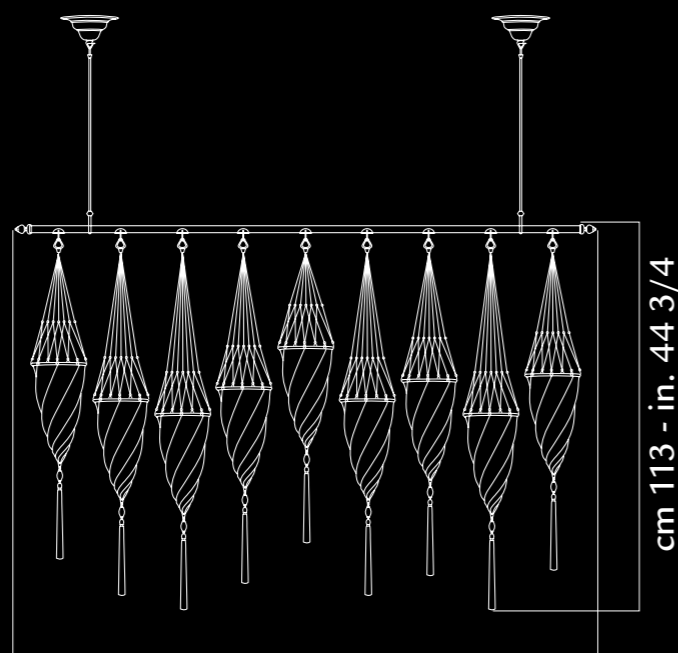

cm 170 - in. 66 7/8

art. AF 017-9

cm 113 - in. 44 3/4

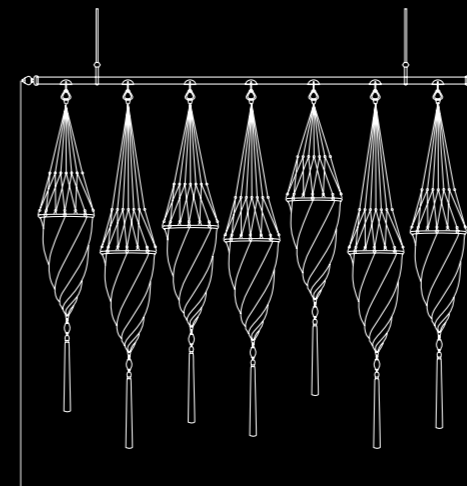

cm 134 - in. 52 3/4

art. AF 017-7

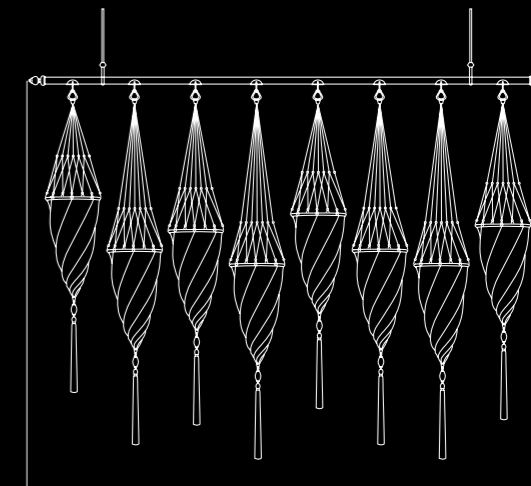

cm 152 - in. 59 7/8

art. AF 017-8





*Cesendello  
floor lamp*

# FOORTYVINTY

CESENDELLO  
FLOOR LAMP

structure: ottone  
fabric: silk  
murano glass beads  
stand covered with fabric  
base: cast iron  
base cover: velvet  
max 25 watt



Red

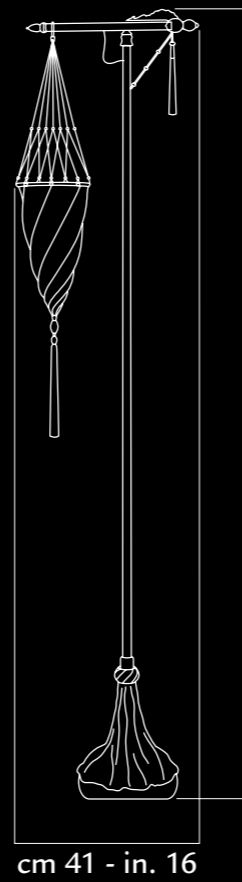

cm 41 - in. 16

cm 174 - in. 68 1/2

art. 174 ST



Green

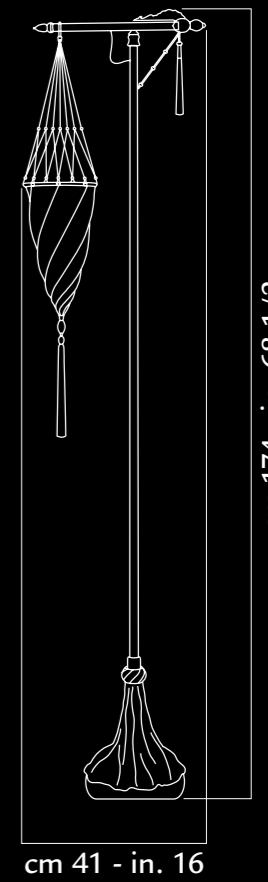

cm 41 - in. 16

cm 174 - in. 68 1/2

art. 174 ST

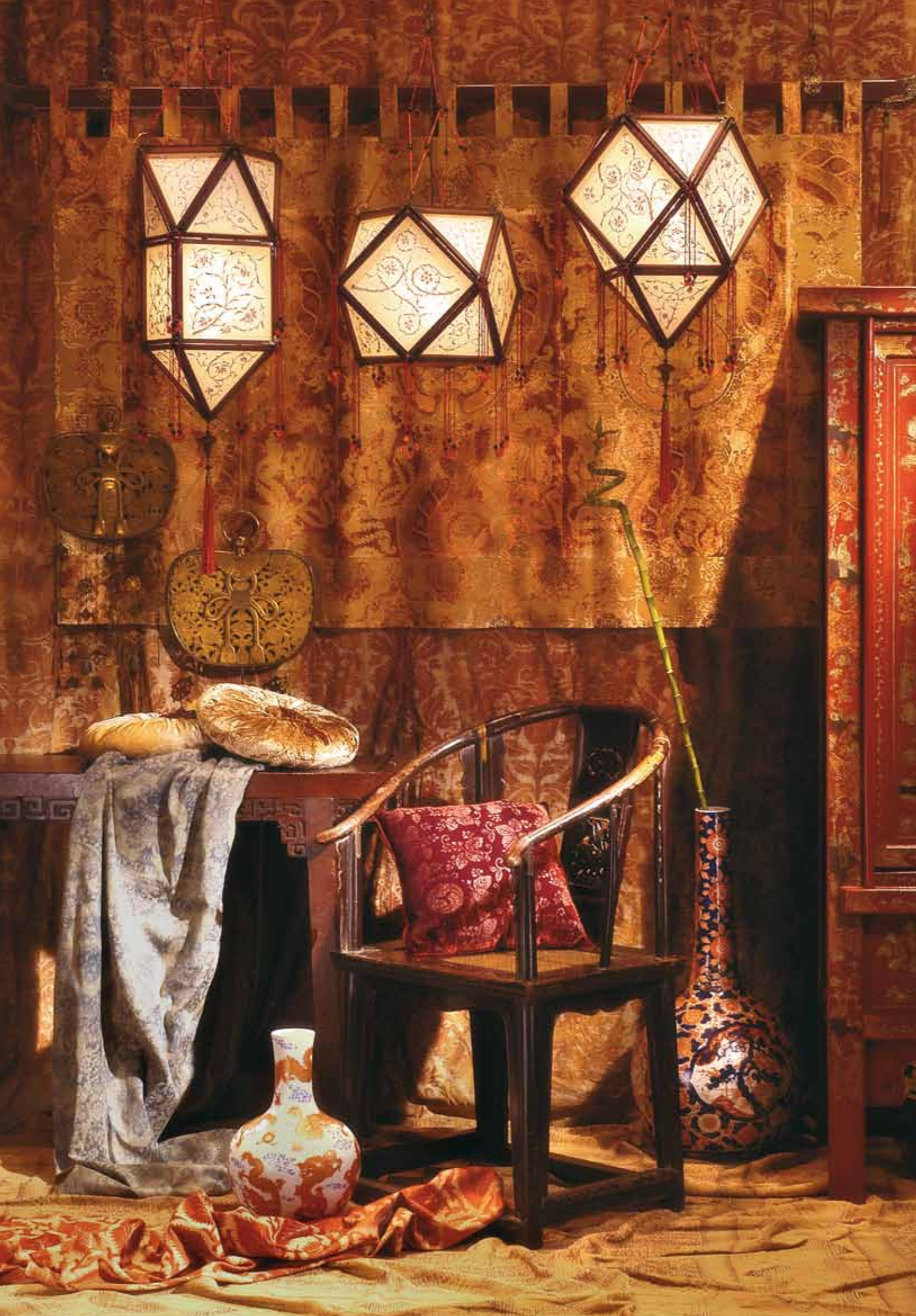

*Concubine*

# FOURTYNINE

PEONIA

structure: wood, brass  
fabric: silk  
murano glass beads  
60 watt

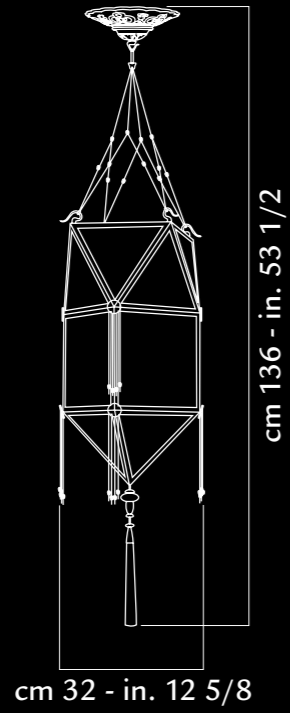

art. 09 PEO



IMPERIALE

structure: wood, brass  
fabric: silk  
murano glass beads  
75 watt

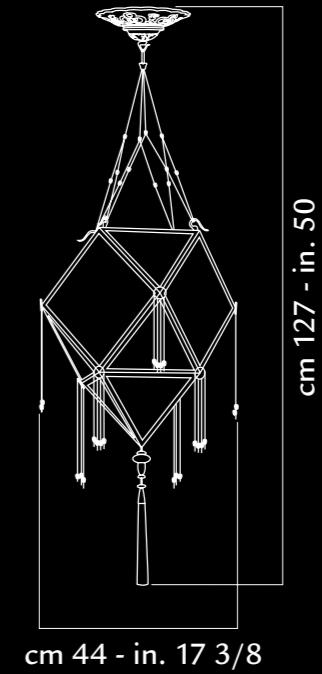

art. 09 IMP

TEMPIO

structure: wood, brass  
fabric: silk  
murano glass beads  
75 watt

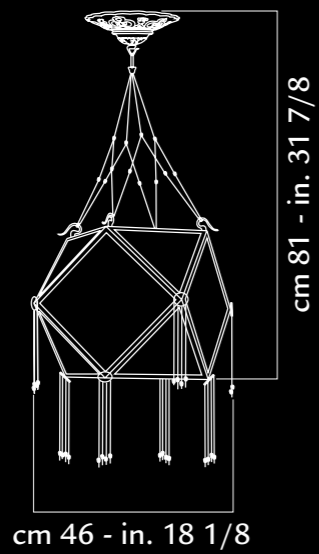

art. 09 TEM



FAVORITA

structure: wood, brass  
fabric: silk  
murano glass beads  
60 watt

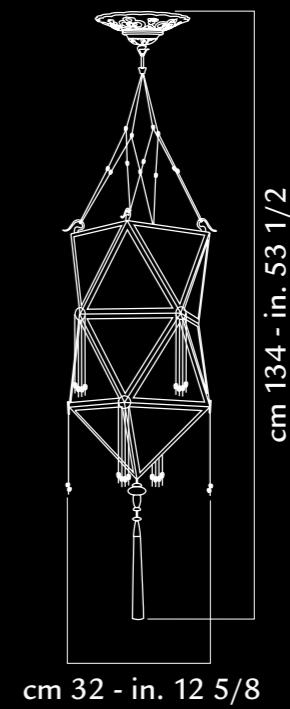

art. 09 FAV

LOTO

structure: wood, brass  
fabric: silk  
murano glass beads  
75 watt

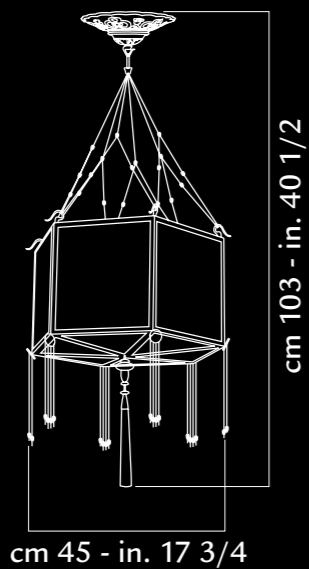

cm 45 - in. 17 3/4

art. 09 LOT

cm 103 - in. 40 1/2



PROIBITA

structure: wood, brass  
fabric: silk  
murano glass beads  
75 watt

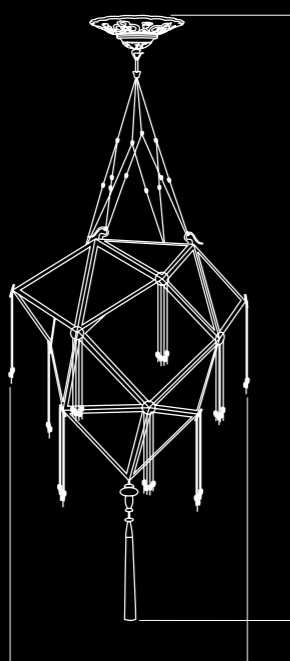

cm 53 - in. 20 7/8

art. 09 PRO

cm 132 - in. 52





## GLASS LAMPS

Nella versione in vetro delle lampade FORTUNY®, Venetia Studium continua la secolare tradizione dei maestri vetrai veneziani, mantenendo nelle forme l'eleganza e l'originalità della seta. La lucentezza e la trasparenza del vetro esalta i raffinati decori in oro, resi ancor più preziosi dall'accostamento al metallo brunito delle corone traforate. Tutti i modelli proposti sono disponibili con ghiera o con corona.

In the glass range of the FORTUNY® lamps, Venetia Studium continues the centuries-old tradition of the Venetian master glass blowers, while retaining the elegance and originality of the shapes found in the silk version. The brilliance and transparency of the glass enhance the delicate gold decoration, made even more precious by the burnished metal of the decorative metal ring. All models proposed are available with either a metal rim or a decorative metal ring.



*Scudo Saraceno*

# FOORTVINY



SCUDO  
SARACENO  
WITH METAL RING

structure: glass, brass  
burnished metal  
murano glass beads  
100 watt

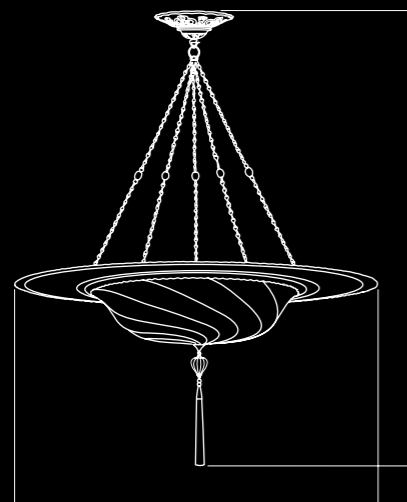

cm 84 - in. 33  
cm 96 - in. 37 3/4

cm 129 - in. 50 3/4  
cm 142 - in. 55 7/8

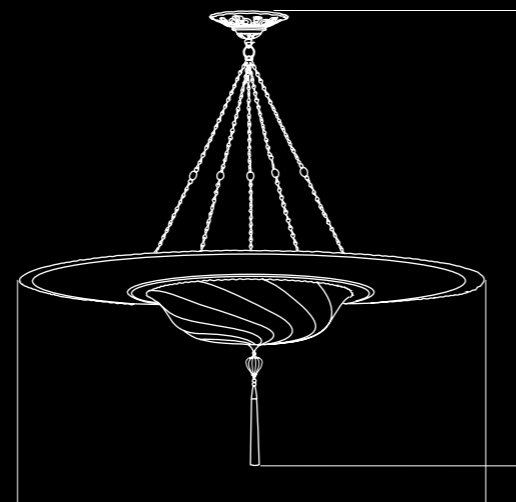

cm 114 - in. 44 7/8  
cm 126 - in. 49 5/8

cm 129 - in. 50 3/4  
cm 142 - in. 55 7/8

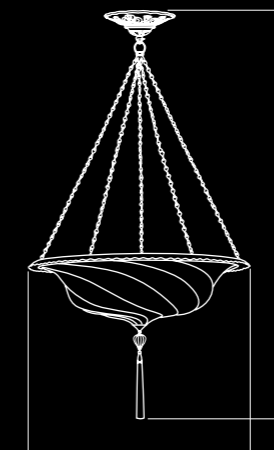

cm 54,5 - in. 21 1/2  
cm 65 - in. 25 5/8

cm 127 - in. 50  
cm 140 - in. 55 1/8

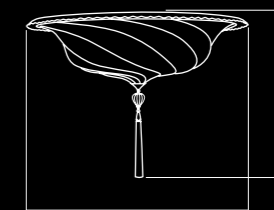

cm 54,5 - in. 21 1/2  
cm 65 - in. 25 5/8

cm 47,5 - in. 18 3/4  
cm 49,5 - in. 19 1/2

SCUDO  
SARACENO

structure: glass, brass  
burnished metal  
murano glass beads  
60/100 watt

art. XG 084 SAC  
art. XG 096 SAC

art. XG 114 SAC  
art. XG 126 SAC

art. XG 055 SA-1  
art. XG 065 SA-1

art. XG 055 SA-1  
art. XG 065 SA-1





*Samarkanda*

# FOURTYNINE

Palazzo Stern . Venice, Italy

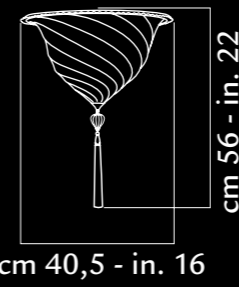
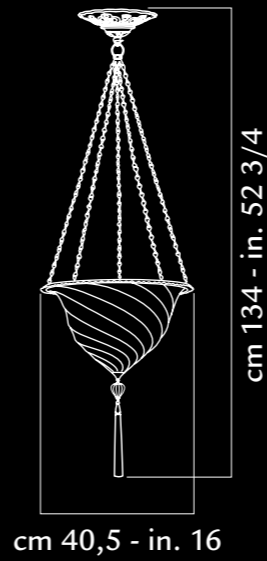

SAMARKANDA

structure: glass, brass  
burnished metal  
murano glass beads  
60/100 watt

art. XG 041 SK-1 art. XG 041 SK-2

SAMARKANDA  
WITH METAL RING

structure: glass, brass  
burnished metal  
murano glass beads  
100 watt

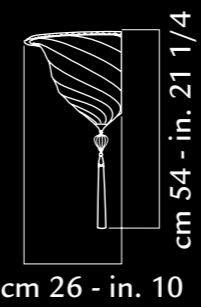
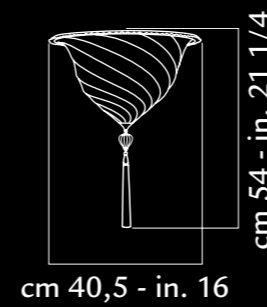
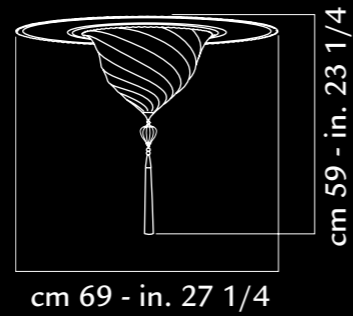
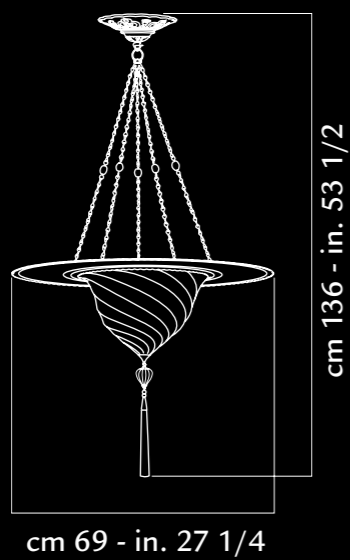

SAMARKANDA  
APPLIQUE

structure: glass, brass  
burnished metal  
murano glass beads  
100 watt

art. XG 069 SKC-1

art. XG 069 SKC-2

art. XG 041 AP

# FOR TWINNY

*Cesendello*



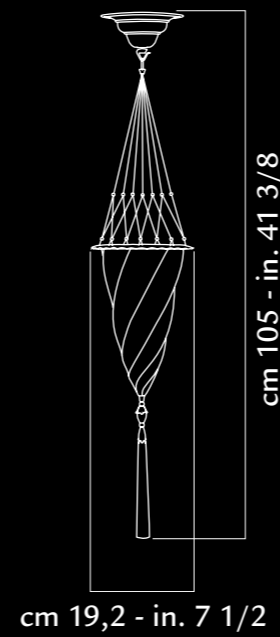

art. G 019 CE-1

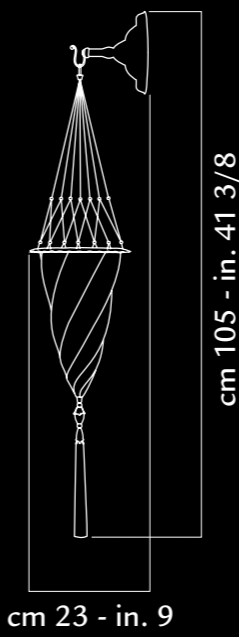

art. G 019 CE-2



CESENDELLO

structure: glass, brass  
burnished metal  
murano glass beads  
60 watt

CESENDELLO  
WITH METAL RING

structure: glass, brass  
burnished metal  
murano glass beads  
60 watt

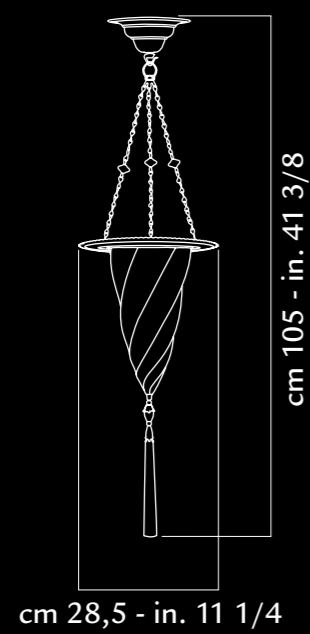

art. G 029 CEC-1

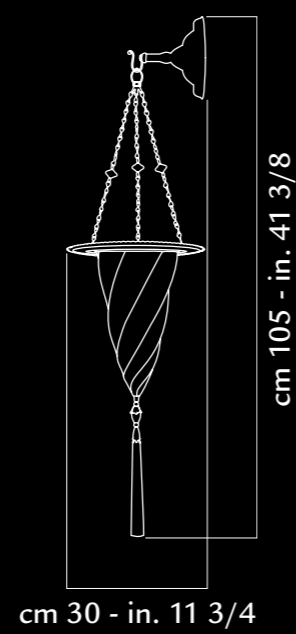

art. G 029 CEC-2

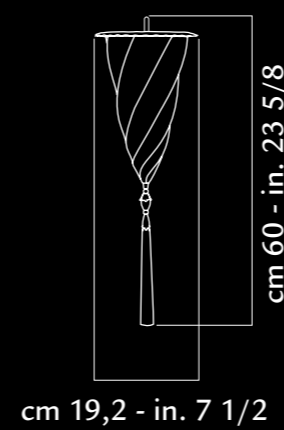

art. G 019 AP

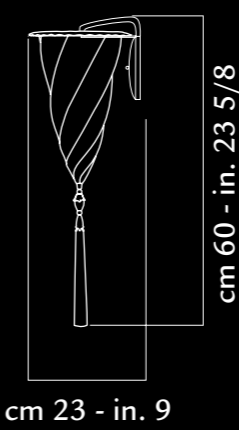

CESENDELLO  
APPLIQUE

structure: glass, brass  
burnished metal  
murano glass beads  
60 watt



CESENDELLO  
APPLIQUE-3

structure: glass, brass  
burnished metal  
murano glass beads  
60 watt

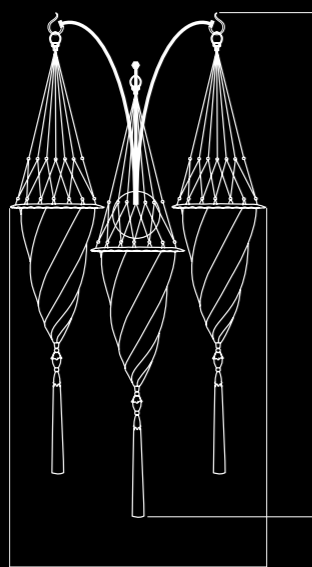

cm 52 - in. 20 3/8

cm 110 - in. 43

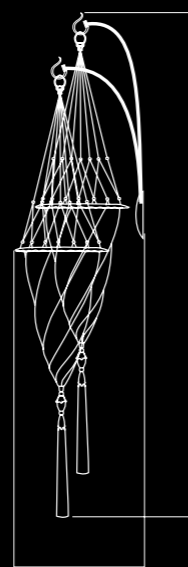

cm 26 - in. 10 1/8

cm 110 - in. 43



CESENDELLO  
APPLIQUE-1

structure: glass, brass  
burnished metal  
murano glass beads  
60 watt

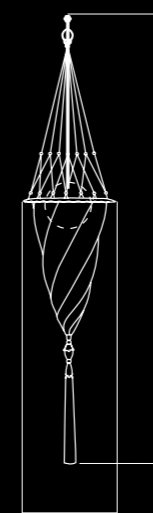

cm 19,2 - in. 7 1/2

cm 85 - in. 33 1/8

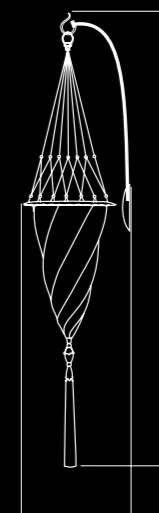

cm 24 - in. 9 3/8

cm 85 - in. 33 1/8



CESENDELLI  
ON A ROD

structure: glass, brass  
burnished metal  
murano glass beads  
rod covered with fabric  
max 60 watt (x 9)

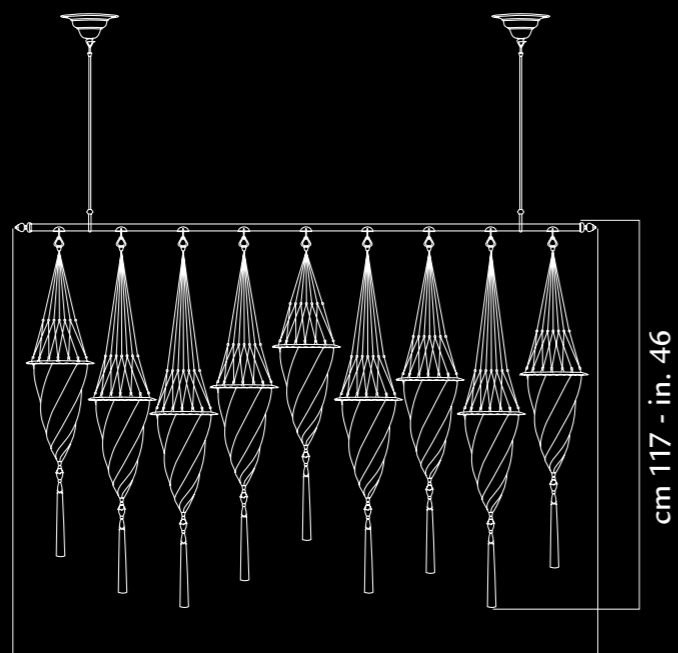

cm 170 - in. 66 7/8

cm 117 - in. 46

art. G AF 019-9

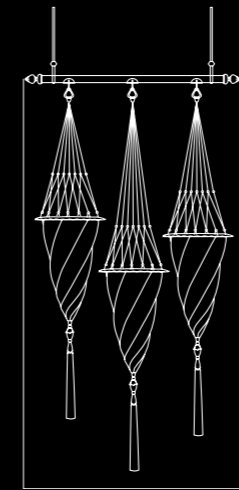

cm 62 - in. 24 3/8

art. G AF 019-3

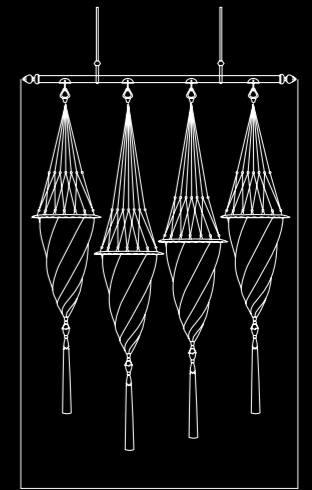

cm 80 - in. 31 1/2

art. G AF 019-4

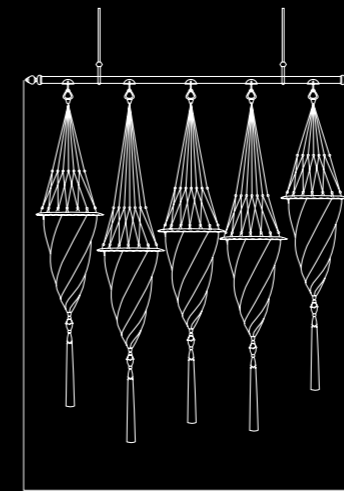

cm 98 - in. 38 5/8

art. G AF 019-5

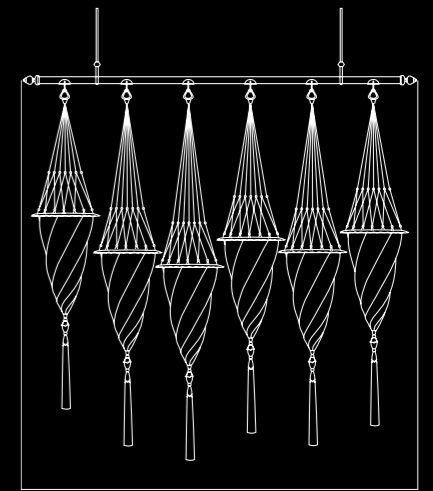

cm 116 - in. 45 2/3

art. G AF 019-6

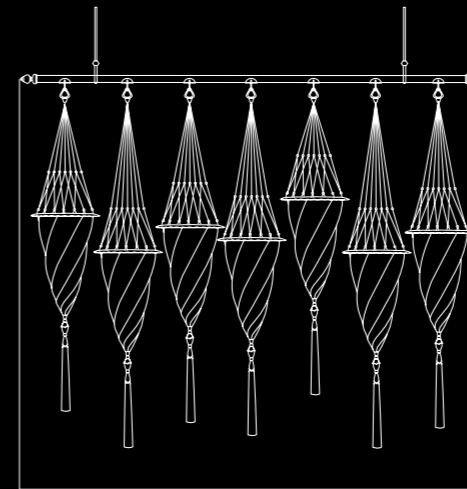

cm 134 - in. 52 3/4

art. G AF 019-7

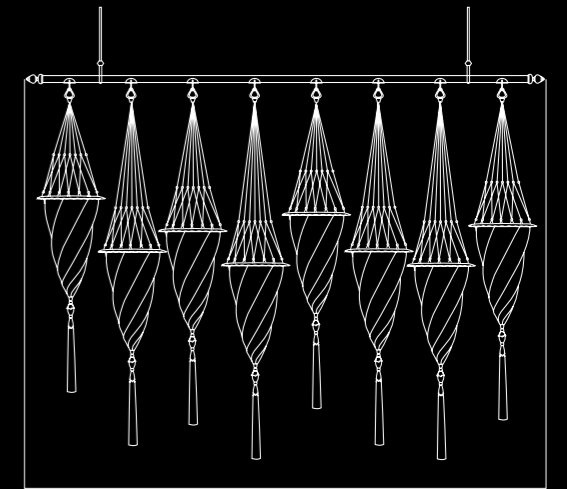

cm 152 - in. 59 7/8

art. G AF 019-8

CESENDELLO  
FLOOR LAMP

structure: glass  
burnished metal  
murano glass beads  
stand covered  
with fabric  
base: cast iron  
base cover: velvet  
60 watt



Red

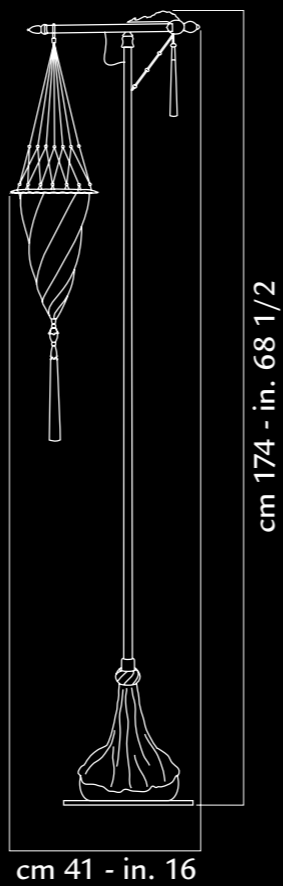

cm 174 - in. 68 1/2

cm 41 - in. 16

art. G 174 ST



Green

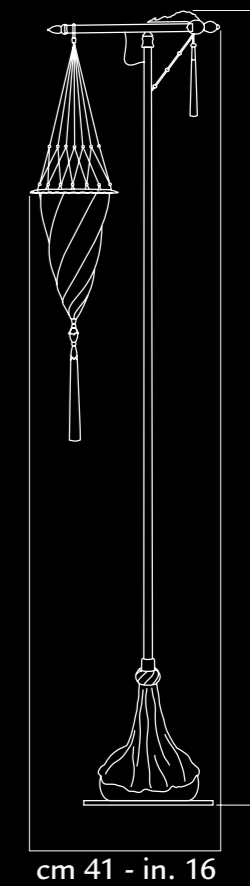

cm 174 - in. 68 1/2

cm 41 - in. 16

art. G 174 ST



# FOR TONY

*Compositions*

Private Villa . Dubai, UAE





SUSPENDED  
COMPOSITION  
33 CESENDELLO

structure: glass, brass  
burnished metal  
murano glass beads  
max 60 watt (x 33)

art. GCM019-33

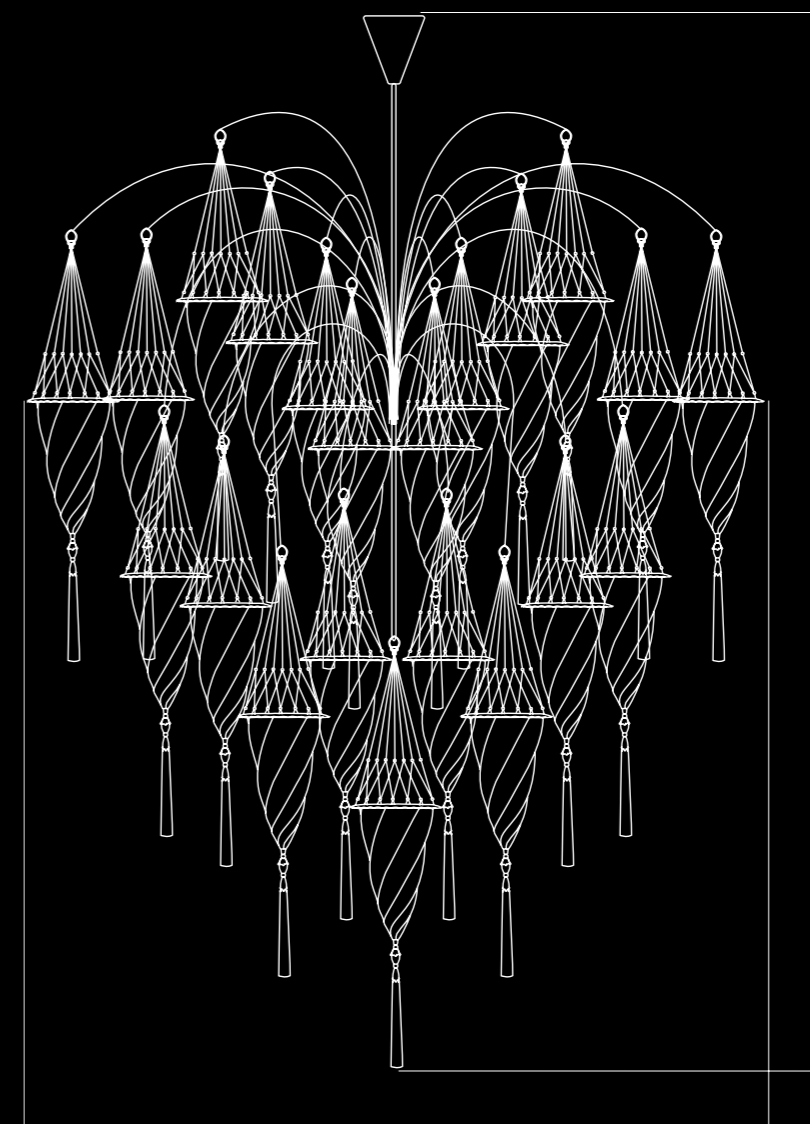

cm 140 - in. 54 5/8

cm 210 - in. 82

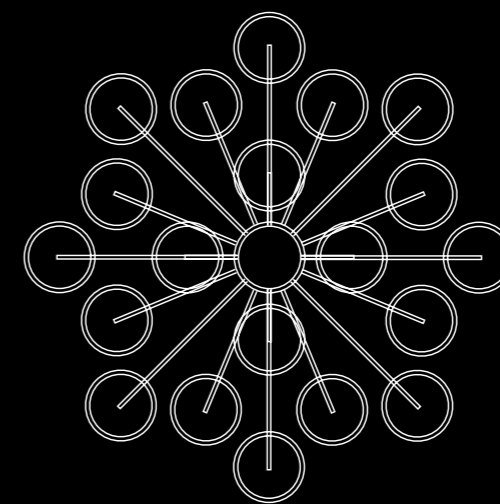

art. GCM019-33



CEILING  
COMPOSITION  
9 CESENDELLO

structure: glass, brass  
burnished metal  
murano glass beads  
max 60 watt (x 9)

art. GCM 019-9

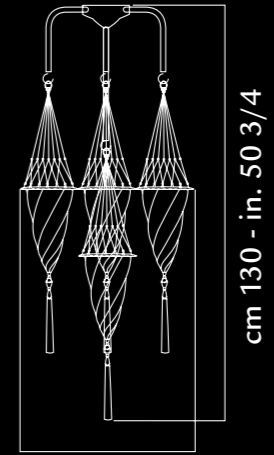
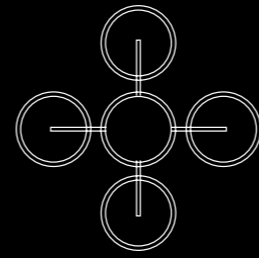

cm 130 - in. 50 3/4

cm 60 - in. 23 3/8

art. GCM 019-5

CEILING  
COMPOSITION  
5 CESENDELLO

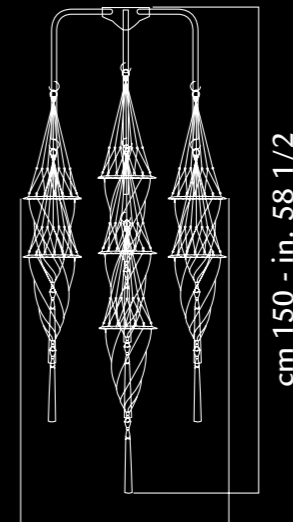
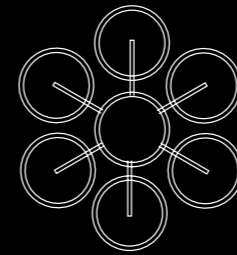

cm 150 - in. 58 1/2

cm 70 - in. 27 1/4

art. GCM 019-7

CEILING  
COMPOSITION  
7 CESENDELLO

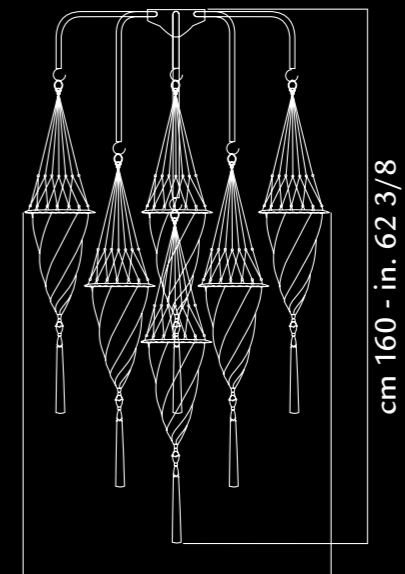
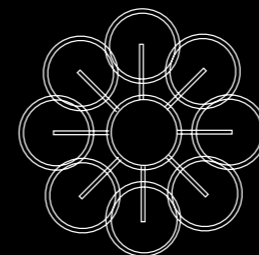

cm 160 - in. 62 3/8

cm 80 - in. 31 1/4

art. GCM 019-9

CEILING  
COMPOSITION  
9 CESENDELLO



SULTANO  
SCUDO SARACENO  
WITH METAL RING  
+ 6 Small Cesendello

structure: glass, brass  
burnished metal  
murano glass beads  
100 + 60 (x 6) watt

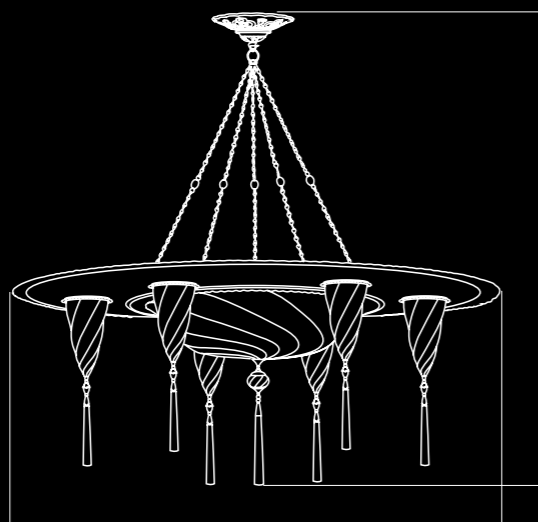

cm 114 - in. 44 7/8  
cm 126 - in. 49 5/8

cm 129 - in. 50 3/4  
cm 142 - in. 55 7/8

art. G 114 SAC-6  
art. G 126 SAC-6

SULTANO  
SAMARKANDA  
WITH METAL RING  
+ 3 Small Cesendello

structure: glass, brass  
burnished metal  
murano glass beads  
100 + 60 (x 3) watt

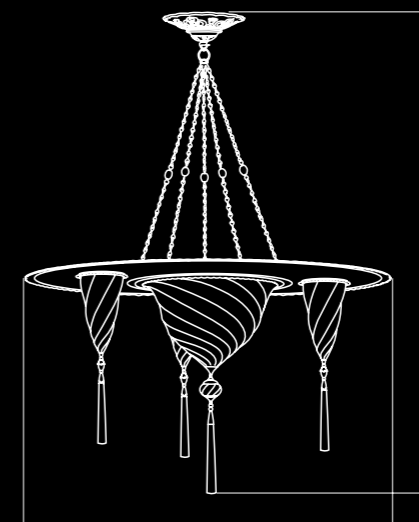

cm 98 - in. 38 5/8

cm 136 - in. 53 1/2

art. G 098 SKC-3



SULTANO  
CESENDELLO  
WITH METAL RING  
+ 3 Small Cesendello

structure: glass, brass  
burnished metal  
murano glass beads  
60 + 60 (x 3) watt

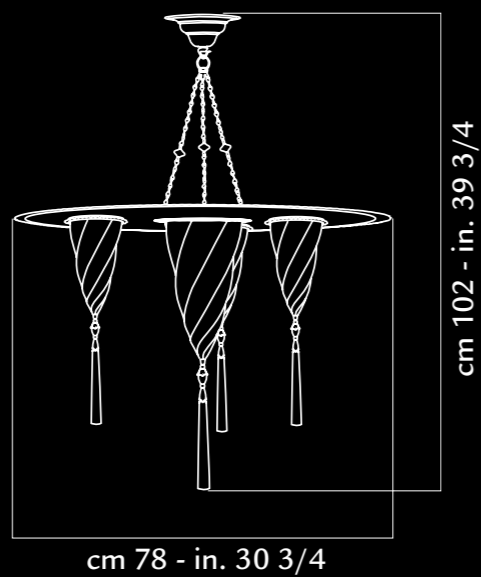

art. G 078 CEC-3



CESENDELLO  
WITH METAL RING

structure: glass, brass  
burnished metal  
murano glass beads  
60 watt

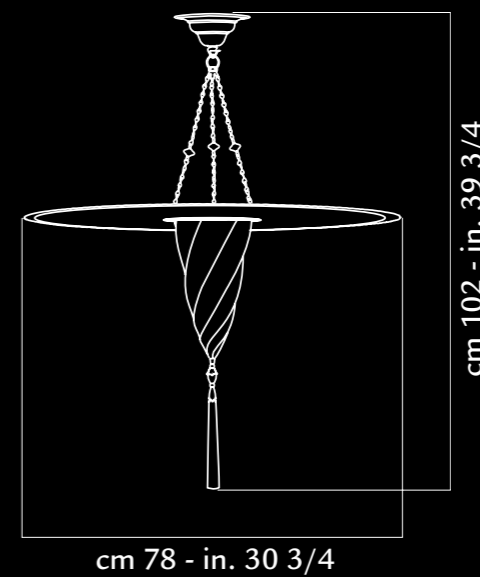

















art. G 078 CEC



*Technical information*

# FOR OPTIVNY













# LAMPADE IN SETA - SILK LAMPS FORTVNY®

	Pag.	Lampada Lamp	Cod.	Ø	Peso Weight	Watt	Altezza totale/Overall height standard min max			Tipologia Typology
	6	SCHEHERAZADE corona traforata / metal ring	185 SHC	cm 185 in. 72 7/8	kg. 26 lb.57 oz.5	max 5 x 100 E27	cm 226 in. 88 1/8	cm 178 in. 69 3/8		Sospensione Suspension
	10	SCHEHERAZADE	126 SH	cm 125,5 in. 49 3/8	kg. 4,4 lb.9 oz.11	max 4 x 100 E27	cm 187 in. 73	cm 137 in. 53 1/2	cm 192 in. 74 7/8	Sospensione Suspension
		SCHEHERAZADE	126 SH-2	cm 125,5 in. 49 3/8	kg. 6,5 lb.14 oz.5	1 x 100 E27	cm 75 in. 29 1/4			Plafoniera Ceiling
	14	SCHEHERAZADE 2 elementi / 2 tiers corona traforata / metal ring	125 SHC	cm 125 in. 49 1/4	kg. 7 lb.15 oz.7	max 100 E27	cm 177 in. 69 5/8	cm 104 in. 40 1/2		Sospensione Suspension
	18	SCHEHERAZADE 2 elementi / 2 tiers	086 SH	cm 86 in. 33 7/8	kg. 1,8 lb.3 oz.15	max 100 E27	cm 177 in. 69 5/8	cm 117 in. 46	cm 182 in. 71 5/8	Sospensione Suspension
		SCHEHERAZADE 2 elementi / 2 tiers	086 SH-2	cm 86 in. 33 7/8	kg. 4 lb.8 oz.13	1 x 75 E27	cm 68 in. 26 3/4			Plafoniera Ceiling
	22	SCUDO SARACENO medio - corona traforata medium size - metal ring	X 096 SAC	cm 96 in. 37 3/4	kg. 5,5 lb.12	75 E27	cm 139,5 in. 55	cm 77,5 in. 30 1/4		Sospensione Suspension
	22	SCUDO SARACENO medio - corona traforata medium size - metal ring	X 126 SAC	cm 126 in. 49 5/8	kg. 7 lb.15 oz.7	75 E27	cm 139,5 in. 55	cm 77,5 in. 30 1/4		Sospensione Suspension
	22	SCUDO SARACENO piccolo - corona traforata small size - metal ring	X 084 SAC	cm 84 in. 33	kg. 4,2 lb.9 oz.4	60 E27	cm 127 in. 50	cm 76 in. 29 5/8		Sospensione Suspension
	22	SCUDO SARACENO piccolo - corona traforata small size - metal ring	X 114 SAC	cm 114 in. 44 7/8	kg. 6,5 lb.14 oz.2	60 E27	cm 127 in. 50	cm 76 in. 29 5/8		Sospensione Suspension
	26	SCUDO SARACENO grande / large size	079 SA	cm 78,5 in. 30 7/8	kg. 1,4 lb.3 oz.10	75/100 E27	cm 158,5 in. 62 3/8	cm 95,5 in. 37 5/8	cm 163,5 in. 64 3/8	Sospensione Suspension
		SCUDO SARACENO grande / large size	079 SA-2	cm 78,5 in. 30 7/8	kg. 2,4 lb.5 oz.5	3 x 60 E14	cm 50 in. 19 3/4			Plafoniera Ceiling
	26	SCUDO SARACENO medio / medium size	062 SA	cm 61,5 in. 24 1/4	kg. 1 lb.2 oz.3	75 E27	cm 134,5 in. 53	cm 90,5 in. 35 5/8	cm 160,5 in. 63 1/8	Sospensione Suspension
		SCUDO SARACENO medio / medium size	062 SA-2	cm 61,5 in. 24 1/4	kg. 2 lb.4 oz.7	3 x 40 E14	cm 47 in. 18 1/2			Plafoniera Ceiling
	26	SCUDO SARACENO piccolo / small size	050 SA	cm 50 in. 19 3/4	kg.0,7 lb.1 oz.8	60 E27	cm 122 in. 48	cm 84 in. 33	cm 159 in. 62 5/8	Sospensione Suspension
		SCUDO SARACENO piccolo / small size	050 SA-2	cm 50 in. 19 3/4	kg.1,7 lb.3 oz.12	3 x 40 E14	cm 46 in. 18			Plafoniera Ceiling

# LAMPADE IN SETA - SILK LAMPS FORTVNY®

Materiali Materials	Colori seta Colours silk	Colori decorazione Colours of decoration	Decorazione Pattern
Seta, ottone, perle di Murano, metallo brunito Silk, brass, Murano glass beads, burnished metal	Avorio Ivory	Marrone, Verde Brown, Green	Floreale, Geometrico, Herbarium, Neutro Floral, Geometric, Herbarium, Plain
Seta, ottone, perle di Murano Silk, brass, Murano glass beads	Avorio Ivory	Marrone, Verde Brown, Green	Floreale, Geometrico, Herbarium, Neutro Floral, Geometric, Herbarium, Plain
Seta, ottone, perle di Murano Silk, brass, Murano glass beads	Avorio Ivory	Marrone, Verde Brown, Green	Floreale, Geometrico, Herbarium, Neutro Floral, Geometric, Herbarium, Plain
Seta, ottone, perle di Murano, metallo brunito Silk, brass, Murano glass beads, burnished metal	Avorio Ivory	Marrone, Verde Brown, Green	Floreale, Geometrico, Herbarium, Neutro Floral, Geometric, Herbarium, Plain
Seta, ottone, perle di Murano Silk, brass, Murano glass beads	Avorio Ivory	Marrone, Verde Brown, Green	Floreale, Geometrico, Herbarium, Neutro Floral, Geometric, Herbarium, Plain
Seta, ottone, perle di Murano Silk, brass, Murano glass beads	Avorio Ivory	Marrone, Verde Brown, Green	Floreale, Geometrico, Herbarium, Neutro Floral, Geometric, Herbarium, Plain
Seta, ottone, perle di Murano, metallo brunito Silk, brass, Murano glass beads, burnished metal	Avorio, Ocra, Salvia, Salmone Ivory, Ochre, Sage grey, Salmon		Classico, Serpentina, Cardo, Neutro Classic, Serpentine, Carduus, Plain
Seta, ottone, perle di Murano, metallo brunito Silk, brass, Murano glass beads, burnished metal	Avorio, Ocra, Salvia, Salmone Ivory, Ochre, Sage grey, Salmon		Classico, Serpentina, Cardo, Neutro Classic, Serpentine, Carduus, Plain
Seta, ottone, perle di Murano, metallo brunito Silk, brass, Murano glass beads, burnished metal	Avorio, Ocra, Salvia, Salmone Ivory, Ochre, Sage grey, Salmon		Classico, Serpentina, Cardo, Neutro Classic, Serpentine, Carduus, Plain
Seta, ottone, perle di Murano, metallo brunito Silk, brass, Murano glass beads, burnished metal	Avorio, Ocra, Salvia, Salmone Ivory, Ochre, Sage grey, Salmon		Classico, Serpentina, Cardo, Neutro Classic, Serpentine, Carduus, Plain
Seta, ottone, perle di Murano Silk, brass, Murano glass beads	Avorio, Ocra, Salvia, Salmone Ivory, Ochre, Sage grey, Salmon		Classico, Serpentina, Cardo, Neutro Classic, Serpentine, Carduus, Plain
Seta, ottone, perle di Murano Silk, brass, Murano glass beads	Avorio, Ocra, Salvia, Salmone Ivory, Ochre, Sage grey, Salmon		Classico, Serpentina, Cardo, Neutro Classic, Serpentine, Carduus, Plain
Seta, ottone, perle di Murano Silk, brass, Murano glass beads	Avorio, Ocra, Salvia, Salmone Ivory, Ochre, Sage grey, Salmon		Classico, Serpentina, Cardo, Neutro Classic, Serpentine, Carduus, Plain
Seta, ottone, perle di Murano Silk, brass, Murano glass beads	Avorio, Ocra, Salvia, Salmone Ivory, Ochre, Sage grey, Salmon		Classico, Serpentina, Cardo, Neutro Classic, Serpentine, Carduus, Plain

# LAMPADE IN SETA - SILK LAMPS FORTVNY®

	Pag.	Lampada Lamp	Cod.	Ø	Peso Weight	Watt	Altezza totale/Overall height standard min max			Tipologia Typology
	30	SAMARKANDA corona traforata / metal ring	X 069 SKC	cm 69 in. 27 1/4	kg. 2,9 lb.6 oz.6	60 E27	cm 135 in. 53 1/8	cm 79 in. 30 1/4		Sospensione Suspension
	34	SAMARKANDA con disco / with disk	124 SD	cm 124 in. 48 7/8	kg. 1,5 lb.3 oz.5	60/75 E27	cm 162 in. 63 3/4	cm 102 in. 40 1/8	cm 167 in. 65 3/4	Sospensione Suspension
	34	SAMARKANDA	037 SK	cm 36,5 in. 14 3/8	kg. 0,4 oz.14	60 E27	cm 130 in. 51 1/8	cm 92 in. 36 1/4	cm 167 in. 65 3/4	Sospensione Suspension
		SAMARKANDA	037 SK-2	cm 36,5 in. 14 3/8	kg. 1,5 lb.3 oz.5	3 x 25 E14	cm 54 in. 21 1/4			Plafoniera Ceiling
	40	CESENDELLO grande / large size	017 CE	cm 17 in. 6 3/4	kg. 0,2 oz.7	max 25 E14	cm 98 in. 38 5/8	cm 95 in. 37 3/8	cm 219 in. 86 1/4	Sospensione/ A parete Suspension / Wall
	44	CESENDELLI su asta / on a rod*	AF 017	cm 17 in. 6 3/4 (each shade)	kg. 0,2 oz.7 (each shade)	25 E14 (each shade)	Composizioni multiple disponibili per min. 3 - max 9 lampade Cesendello Multiple composition is available for min. 3 - max 9 Cesendello shades			Sospensione/ A parete Suspension / Wall
	46	CESENDELLO stelo / floor lamp*	174 ST	cm 17 in. 6 3/4	kg. 6,3 lb.13 oz.14	max 25 E14	cm 174 in. 68 1/2			Da terra Floor
	50	PEONIA	09 PEO	cm 32 in. 12 5/8	kg. 1,1 lb.2 oz.7	60 E14	cm 136 in. 53 1/2	cm 132 in. 52	cm 167 in. 65 3/4	Sospensione Suspension
	50	TEMPIO	09 TEM	cm 46 in. 18 1/8	kg. 0,9 lb.2	75 E27	cm 81 in. 31 7/8	cm 77 in. 30 1/4	cm 112 in. 44	Sospensione Suspension
	50	IMPERIALE	09 IMP	cm 44 in. 17 3/8	kg. 1,1 lb.2 oz.7	75 E27	cm 127 in. 50	cm 123 in. 48 3/8	cm 158 in. 62 1/4	Sospensione Suspension
	50	FAVORITA	09 FAV	cm 32 in. 12 5/8	kg. 1,2 lb.2 oz.10	60 E14	cm 134 in. 53 1/2	cm 130 in. 51 1/4	cm 165 in. 65	Sospensione Suspension
	50	LOTO	09 LOT	cm 45 in. 17 3/4	kg. 0,9 lb.2	75 E27	cm 103 in. 40 1/2	cm 99 in. 39	cm 134 in. 52 3/4	Sospensione Suspension
	50	PROIBITA	09 PRO	cm 53 in. 20 7/8	kg. 1,5 lb.3 oz.5	75 E27	cm 132 in. 50	cm 128 in. 50 3/8	cm 163 in. 64	Sospensione Suspension

















\*Asta e Stelo: Metallo rivestito di cotone stampato, Bordeaux, Verde (cotone)  
Rod and Stand: Metal covered with printed cotton, Bordeaux, Green (cotton)

# LAMPADE IN SETA - SILK LAMPS FORTVNY®

Materiali Materials	Colori seta Colours silk	Colori decorazione Colours of decoration	Decorazione Pattern
Seta, ottone, perle di Murano, metallo brunito Silk, brass, Murano glass beads, burnished metal	Avorio Ivory		Decò, Serpentina, Neutro Decò, Serpentine, Plain
Seta, ottone, perle di Murano Silk, brass, Murano glass beads	Avorio Ivory		Decò, Serpentina, Neutro Decò, Serpentine, Plain
Seta, ottone, perle di Murano Silk, brass, Murano glass beads	Avorio Ivory		Decò, Serpentina, Neutro Decò, Serpentine, Plain
Seta, ottone, perle di Murano Silk, brass, Murano glass beads	Avorio Ivory		Decò, Serpentina, Neutro Decò, Serpentine, Plain
Seta, ottone, perle di Murano Silk, brass, Murano glass beads	Avorio, Ocra, Salvia, Salmone Ivory, Ochre, Sage grey, Salmon		Standard, Neutro Standard, Plain
Seta, ottone, perle di Murano Silk, brass, Murano glass beads	Avorio, Ocra, Salvia, Salmone Ivory, Ochre, Sage grey, Salmon		Standard, Neutro Standard, Plain
Seta, ottone, perle di Murano Silk, brass, Murano glass beads	Avorio, Ocra, Salvia, Salmone Ivory, Ochre, Sage grey, Salmon		Standard, Neutro Standard, Plain
Seta, legno, ottone, perle di Murano Silk, wood, brass, Murano glass beads	Avorio Ivory		Standard, Neutro Standard, Plain
Seta, legno, ottone, perle di Murano Silk, wood, brass, Murano glass beads	Avorio Ivory		Standard, Neutro Standard, Plain
Seta, legno, ottone, perle di Murano Silk, wood, brass, Murano glass beads	Avorio Ivory		Standard, Neutro Standard, Plain
Seta, legno, ottone, perle di Murano Silk, wood, brass, Murano glass beads	Avorio Ivory		Standard, Neutro Standard, Plain
Seta, legno, ottone, perle di Murano Silk, wood, brass, Murano glass beads	Avorio Ivory		Standard, Neutro Standard, Plain

# LAMPADE IN VETRO - GLASS LAMPS

## FORTVNY®

	Pag.	Lampada Lamp	Cod.	Ø	Peso Weight	Watt	Altezza totale/Overall height standard min max		
	58	SCUDO SARACENO medio - corona traforata medium size - metal ring	XG 096 SAC	cm 96 in. 37 3/4	kg. 10 lb.22 oz.1	100 E27	cm 142 in. 55 7/8	cm 80 in. 31 1/4	
	58	SCUDO SARACENO medio - corona traforata medium size - metal ring	XG 126 SAC	cm 126 in. 49 5/8	kg. 13,4 lb.29 oz.9	100 E27	cm 142 in. 55 7/8	cm 80 in. 31 1/4	
	58	SCUDO SARACENO piccolo - corona traforata small size - metal ring	XG 084 SAC	cm 84 in. 33	kg. 8,6 lb.18 oz.15	100 E27	cm 129 in. 50 3/4	cm 78 in. 30 3/8	
	58	SCUDO SARACENO piccolo - corona traforata small size - metal ring	XG 114 SAC	cm 114 in. 44 7/8	kg. 11 lb.24 oz.4	100 E27	cm 129 in. 50 3/4	cm 78 in. 30 3/8	
	61	SCUDO SARACENO medio / medium size	XG 065 SA	cm 65 in. 25 5/8	kg. 6,7 lb.14 oz.12	100 E27	cm 140 in. 55 1/8	cm 78 in. 30 3/8	cm 166 in. 65 3/8
	61	SCUDO SARACENO medio / medium size	XG 065 SA-2	cm 65 in. 25 5/8	kg. 10,5 lb.23 oz.2	3 X 40 E14	cm 49,5 in. 19 1/2		
	61	SCUDO SARACENO piccolo / small size	XG 055 SA	cm 54,5 in. 21 1/2	kg. 5 lb.11	100 E27	cm 127 in. 50	cm 76 in. 29 5/8	cm 164 in. 64 1/2
	61	SCUDO SARACENO piccolo / small size	XG 055 SA-2	cm 54,5 in. 21 1/2	kg. 8,5 lb.18 oz.12	3 X 40 E14	cm 47,5 in. 18 3/4		
	62	SAMARKANDA corona traforata / metal ring	XG 069 SKC	cm 69 in. 27 1/4	kg. 5,5 lb.12 oz.2	100 E27	cm 136 in. 53 1/2	cm 80 in. 31 1/4	
	64	SAMARKANDA corona traforata / metal ring	XG 069 SKC-2	cm 69 in. 27 1/4	kg. 10 lb.22 oz.1	100 E14	cm 59 in. 23		
	65	SAMARKANDA	XG 041 SK	cm 40,5 in. 16	kg.2,8 lb.6 oz.3	100 E27	cm 134 in. 52 3/4	cm 78 in. 30 3/8	cm 171 in. 67 3/8
	65	SAMARKANDA	XG 041 SK-2	cm 40,5 in. 16	kg.6,5 lb.14 oz.5	3 x 25 E14	cm 56 in. 22		
	65	SAMARKANDA applique	XG 041 AP	cm 40,5 in. 16	kg.2,8 lb.6 oz.3	100 E27	cm 54 in. 21		
	66	CESENDELLO grande - corona traforata large size - metal ring	G 029 CEC	cm 28,5 in. 11 1/4	kg.1,8 lb.4 oz.1	60 E14	cm 102 in. 39 3/4	cm 88 in. 34 5/8	
	69	CESENDELLO grande / large size	G 019 CE	cm 19,2 in. 7 1/2	kg.1,6 lb.3 oz.8	60 E14	cm 102 in. 39 3/4	cm 97 in. 38 1/8	cm 218 in. 85 3/4
	69	CESENDELLO applique	G 019 AP	cm 19,2 in. 7 1/2	kg.2 lb.4 oz.7	60 E14	cm 62 in. 24 1/8		

# LAMPADE IN VETRO - GLASS LAMPS

## FORTVNY®

Tipologia Typology	Materiali Materials	Colori decorazione Colours of decoration	Decorazione Pattern
Sospensione Suspension	Vetro, ottone, perle di Murano, metallo brunito Glass, brass, Murano glass beads, burnished metal	Argento, Oro Silver, Gold	Classico Classic
Plafoniera Ceiling	Vetro, ottone, perle di Murano, metallo brunito Glass, brass, Murano glass beads, burnished metal	Argento, Oro Silver, Gold	Classico Classic
Sospensione Suspension	Vetro, ottone, perle di Murano, metallo brunito Glass, brass, Murano glass beads, burnished metal	Argento, Oro Silver, Gold	Classico Classic
Sospensione Suspension	Vetro, ottone, perle di Murano, metallo brunito Glass, brass, Murano glass beads, burnished metal	Argento, Oro Silver, Gold	Classico Classic
Sospensione Suspension	Vetro, ottone, perle di Murano, metallo brunito Glass, brass, Murano glass beads, burnished metal	Argento, Oro Silver, Gold	Classico Classic
Plafoniera Ceiling	Vetro, ottone, perle di Murano, metallo brunito Glass, brass, Murano glass beads, burnished metal	Argento, Oro Silver, Gold	Classico Classic
Sospensione Suspension	Vetro, ottone, perle di Murano, metallo brunito Glass, brass, Murano glass beads, burnished metal	Argento, Oro Silver, Gold	Classico Classic
Plafoniera Ceiling	Vetro, ottone, perle di Murano, metallo brunito Glass, brass, Murano glass beads, burnished metal	Argento, Oro Silver, Gold	Classico Classic
Sospensione Suspension	Vetro, ottone, perle di Murano, metallo brunito Glass, brass, Murano glass beads, burnished metal	Argento, Oro Silver, Gold	Classico Classic
Plafoniera Ceiling	Vetro, ottone, perle di Murano, metallo brunito Glass, brass, Murano glass beads, burnished metal	Argento, Oro Silver, Gold	Classico Classic
Sospensione Suspension	Vetro, ottone, perle di Murano, metallo brunito Glass, brass, Murano glass beads, burnished metal	Argento, Oro Silver, Gold	Serpentina Serpentine
Plafoniera Ceiling	Vetro, ottone, perle di Murano, metallo brunito Glass, brass, Murano glass beads, burnished metal	Argento, Oro Silver, Gold	Serpentina Serpentine
Sospensione Suspension	Vetro, ottone, perle di Murano, metallo brunito Glass, brass, Murano glass beads, burnished metal	Argento, Oro Silver, Gold	Serpentina Serpentine
Plafoniera Ceiling	Vetro, ottone, perle di Murano, metallo brunito Glass, brass, Murano glass beads, burnished metal	Argento, Oro Silver, Gold	Serpentina Serpentine
A parete Wall	Vetro, ottone, perle di Murano, metallo brunito Glass, brass, Murano glass beads, burnished metal	Argento, Oro Silver, Gold	Serpentina Serpentine
Sospensione / A parete Suspension / Wall	Vetro, ottone, perle di Murano, metallo brunito Glass, brass, Murano glass beads, burnished metal	Argento, Oro Silver, Gold	Standard Standard
Sospensione / A parete Suspension / Wall	Vetro, ottone, perle di Murano, metallo brunito Glass, brass, Murano glass beads, burnished metal	Argento, Oro Silver, Gold	Standard Standard
A parete Wall	Vetro, ottone, perle di Murano, metallo brunito Glass, brass, Murano glass beads, burnished metal	Argento, Oro Silver, Gold	Standard Standard



# LAMPADE IN VETRO - GLASS LAMPS FORTVNY®

	Pag.	Lampada Lamp	Cod.	Ø	Peso Weight	Watt	Altezza totale/Overall height standard min max	
	70	CESENDELLO triple applique	GCM 019 - 3GC	cm 52 in. 20 1/4	kg.4,8 lb.10 oz.9	60 x 3 E14	cm 110 in. 43	
	71	CESENDELLO arc applique	GCM 019 - 1GC	cm 19,2 in. 7 1/2	kg.1,6 lb.3 oz.8	60 E14	cm 106 in. 41 3/8	
	72	CESENDELLI su asta / on a rod*	G AF 019	cm 19,2 (each shade) in. 7 1/2 (each shade)	kg. 1,6 (each shade) lb.3 oz.8 (each shade)	max 60 (each shade) E14	Composizioni multiple disponibili per min. 3 - max 9 lampade Cesendello Multiple composition is available for min. 3 - max 9 Cesendello shades	
	74	CESENDELLO stelo / floor lamp*	G174 ST	cm 19,2 in. 7 1/2	kg. 7,5 lb.16 oz.9	60 E14	cm 174 in. 68 1/2	
	78	CESENDELLI composizione da 33 33 light pendant	GCM 019 - 33	cm 140 in. 50 5/8	kg. 62 lb.136 oz.11	max 60 (x 33) E14	cm 210 in. 82	
	80	CESENDELLI composizione da 9 9 light pendant	GCM 019 - 9	cm 80 in. 31 1/4	kg. 16 lb.35 oz.4	max 60 (x 9) E14	cm 160 in. 62 3/8	
	81	CESENDELLI composizione da 7 7 light pendant	GCM 019 - 7	cm 70 in. 27 1/4	kg. 12 lb.26 oz.7	max 60 (x 7) E14	cm 165 in. 64 3/8	
	81	CESENDELLI composizione da 5 5 light pendant	GCM 019 - 5	cm 60 in. 23 3/8	kg. 9 lb.19 oz.13	max 60 (x 5) E14	cm 150 in. 58 1/2	
	82	SCUDO SARACENO medio - corona traforata medium size - metal ring	G 126 SAC - 6	cm 126 in. 49 5/8	kg. 18,4 lb.40 oz.9	100 (+ 60 x6) E27/14	cm 142 in. 55 7/8	cm 80 in. 31 1/4
	82	SCUDO SARACENO piccolo - corona traforata small size - metal ring	G 114 SAC - 6	cm 114 in. 44 7/8	kg. 15,3 lb.33 oz.12	100 (+ 60 x6) E27/14	cm 129 in. 50 3/4	cm 78 in. 30 3/8
	83	SAMARKANDA corona traforata / metal ring	G 098 SKC - 3	cm 98 in. 38 5/8	kg. 10,4 lb.22 oz.15	100 (+ 60 x3) E27/14	cm 136 in. 53 1/2	cm 80 in. 31 1/4
	84	CESENDELLO corona traforata / metal ring	G 078 CEC - 3	cm 78 in. 30 3/4	kg. 5,2 lb.15 oz.16	60 (+ 60 x3) E14	cm 102 in. 39 3/4	cm 88 in. 34 5/8
	85	CESENDELLO corona traforata / metal ring	G 078 CEC	cm 78 in. 30 3/4	kg.4,8 lb.11 oz.6	60 E14	cm 102 in. 39 3/4	cm 88 in. 34 5/8

\*Asta e Stelo: Metallo rivestito di cotone stampato, Bordeaux, Verde (cotone)  
Rod and Stand: Metal covered with printed cotton, Bordeaux, Green (cotton)

# LAMPADE IN VETRO - GLASS LAMPS FORTVNY®

Tipologia Typology	Materiali Materials	Colori decorazione Colours of decoration	Decorazione Pattern
A parete Wall	Vetro, ottone, perle di Murano, metallo brunito Glass, brass, Murano glass beads, burnished metal	Argento, Oro Silver, Gold	Standard Standard
A parete Wall	Vetro, ottone, perle di Murano, metallo brunito Glass, brass, Murano glass beads, burnished metal	Argento, Oro Silver, Gold	Standard Standard
Sospensione / A parete Suspension / Wall	Vetro, ottone, perle di Murano, metallo brunito Glass, brass, Murano glass beads, burnished metal	Argento, Oro Silver, Gold	Standard Standard
Da terra Floor	Vetro, ottone, perle di Murano, metallo brunito Glass, brass, Murano glass beads, burnished metal	Argento, Oro Silver, Gold	Standard Standard
Sospensione Suspension	Vetro, ottone, perle di Murano, metallo brunito Glass, brass, Murano glass beads, burnished metal	Argento, Oro Silver, Gold	Standard Standard
Sospensione Suspension	Vetro, ottone, perle di Murano, metallo brunito Glass, brass, Murano glass beads, burnished metal	Argento, Oro Silver, Gold	Standard Standard
Sospensione Suspension	Vetro, ottone, perle di Murano, metallo brunito Glass, brass, Murano glass beads, burnished metal	Argento, Oro Silver, Gold	Standard Standard
Sospensione Suspension	Vetro, ottone, perle di Murano, metallo brunito Glass, brass, Murano glass beads, burnished metal	Argento, Oro Silver, Gold	Standard Standard
Sospensione Suspension	Vetro, ottone, perle di Murano, metallo brunito Glass, brass, Murano glass beads, burnished metal	Argento, Oro Silver, Gold	Classico Classic
Sospensione Suspension	Vetro, ottone, perle di Murano, metallo brunito Glass, brass, Murano glass beads, burnished metal	Argento, Oro Silver, Gold	Classico Classic
Sospensione Suspension	Vetro, ottone, perle di Murano, metallo brunito Glass, brass, Murano glass beads, burnished metal	Argento, Oro Silver, Gold	Serpentina Serpentine
Sospensione Suspension	Vetro, ottone, perle di Murano, metallo brunito Glass, brass, Murano glass beads, burnished metal	Argento, Oro Silver, Gold	Standard Standard
Sospensione Suspension	Vetro, ottone, perle di Murano, metallo brunito Glass, brass, Murano glass beads, burnished metal	Argento, Oro Silver, Gold	Standard Standard

VENETIA STUDIUM S.r.l.

S.Marco 2425  
30124 Venezia  
tel. +39 041 523 6953  
fax +39 041 522 7353

www.venetiastudium.com  
info@venetiastudium.com

Modelli depositati.

Le lampade originali FORTUNY® sono prodotte a Venezia, in esclusiva da Venetia Studium, che ne detiene il marchio a livello mondiale.

Tutte le lampade e gli apparecchi di nostra produzione su richiesta possono essere prodotti per il nord America secondo gli standard UL\* e per l'Europa secondo le normative CE .

L'azienda si riserva la possibilità di apportare delle modifiche alla propria produzione senza alcun impegno di preavviso. I colori presentati in questo catalogo possono differire leggermente da quelli effettivi.

Tutti i tessuti fotografati in questo catalogo sono prodotti e realizzati esclusivamente da Venetia Studium.

Riproduzione vietata.  
Tutti i diritti sono riservati.

Design protected.

The original FORTUNY® lamps are produced exclusively by Venetia Studium, the only company in the world entitled to use the trademark.

On request, all our lamps can be produced for North America according to UL\* standards and for Europe according to CE standards.

The company reserves the right to modify its products without warning. The colours may differ slightly from the colours in this catalogue.

All textiles shown are made exclusively by Venetia Studium

No part of this work may be reproduced or transmitted in any form or by any means without prior permission.  
All rights reserved.

Made in Venice - Italy

\*with the exception of floorstand and rod.



\*eccetto i supporti stelo e asta.

VENETIA  
STVDIVM

