

Barovier&Toso®

INTERIORS

2016



Barovier&Toso®
INTERIORS

2016



Vivere Barovier&Toso è sempre un'emozione, originata da settecento anni di storia sapientemente valorizzati in un processo di reinvenzione continua. Una storia affascinante, che prende avvio nel 1295 – quando un Barovier appare per la prima volta nei documenti storici dell'epoca che parlano della “materia vetro” – e che prosegue di generazione in generazione, superando indenne guerre, epoche, stili e gusti con una capacità di trasformazione e rinnovamento che solo passione e dedizione possono dare.

Experiencing Barovier&Toso is a continuous emotion which originates from seven hundred years of history that are skilfully nurtured in an ongoing reinventive process.

This charming story started in 1295 – the first time a Barovier appeared in the historical documents of the period which discussed “glass material” – and has continued from generation to generation, overcoming wars, eras, styles and tastes unscathed, with an ability for transformation and innovation that only passion and dedication can instil.

Angelo il Grande e il suo “cristallo”,

Ercole e le sue invenzioni e il suo design: separati da cinque secoli eppure così simili nella loro genialità e nella sensibilità, per cogliere il cambiamento che le loro rispettive epoche imponeva per tramandare un'arte fino ai giorni nostri.

Barovier&Toso ancora oggi interpreta il gusto dei tempi, coniugando la tradizione vetraria degli avi con tendenze e innovazioni negli stili e nelle tecnologie, e arricchisce la vita e le emozioni di

Angelo the Great and his “crystal”,

Ercole and his inventions and design:

separated by five centuries, and yet so similar

in their brilliance and sensitivity as to understand the change

that their respective periods imposed in order to pass

on an art to this day and age.

Even today, Barovier&Toso interprets the tastes

of the period by combining the glass tradition

of its forefathers with trends and innovations

in style and technology.

chi sa cogliere le sfumature del “bello”.

Per meglio raccontare queste emozioni, abbiamo raccolto in un libro le suggestioni che un lampadario Barovier&Toso accende quando viene inserito nel contesto di un'abitazione: tre stili abitativi diversi, molte case ma uno stesso ed inimitabile stile Barovier&Toso.

A dimostrazione della versatilità di una creazione che è fatta per essere ammirata, non solo per fare luce.

In doing so, it enhances the life and the emotions of those who know how to capture the nuances of “beauty”.

To better describe these emotions,

we have gathered in a book the splendour that

a Barovier&Toso chandelier ignites when

it's included in a home:

three diverse residential styles.

Many homes, but the same inimitable Barovier&Toso style.

A demonstration of the versatility of a creation which

is made to be admired, and not just to give light.

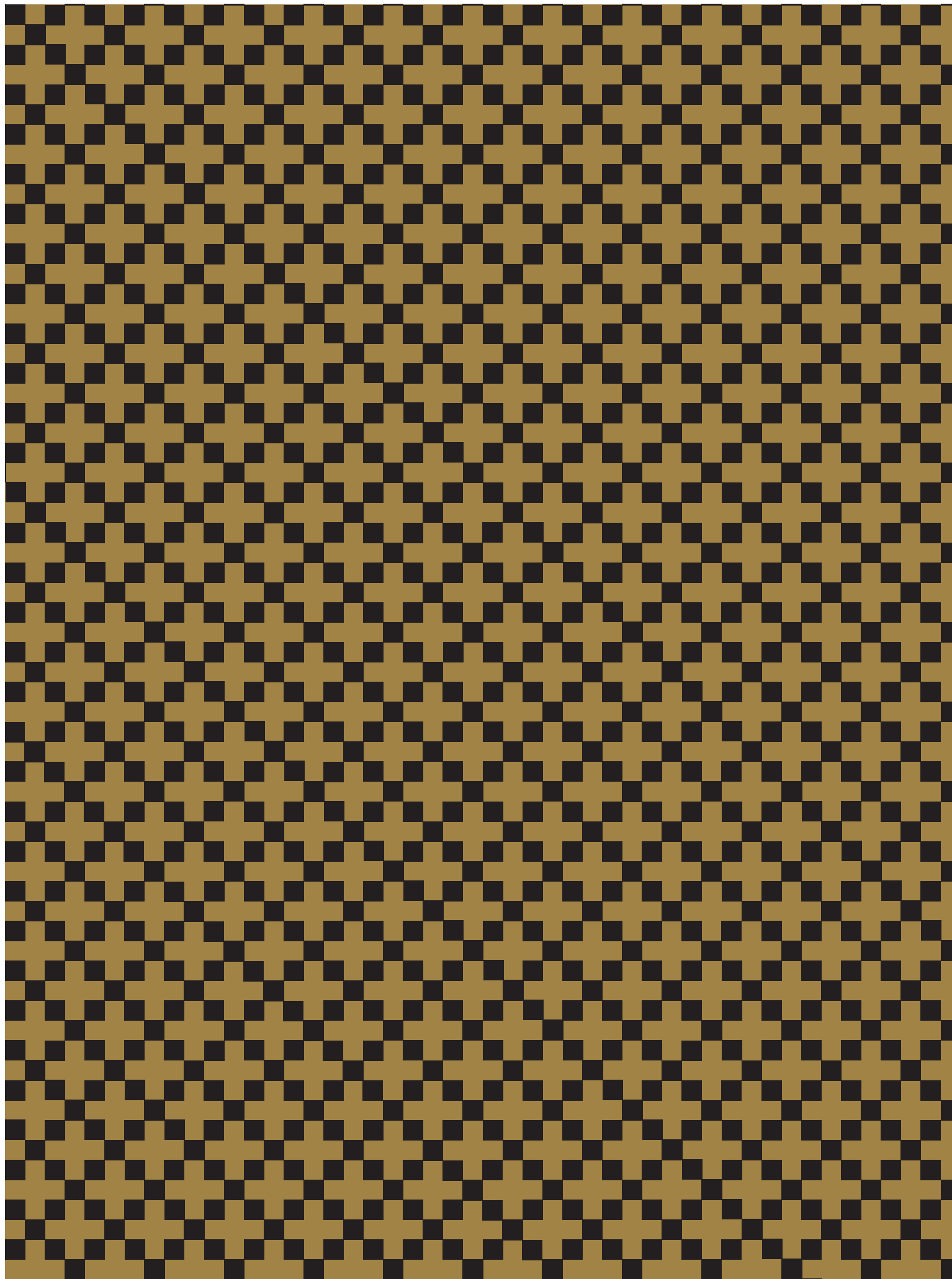





Angel
AI Design 2015







Pandora
Barovier&Toso 2013









Maine
Barovier&Toso 2007













Manhattan
Alessandro Piva 2009





Taif
Barovier&Toso 1980











Optical
Barovier&Toso 2007









Exagon
Barovier&Toso 2010







Samurai
Angelo Barovier 1966/2008













Cechi
Barovier&Toso 2016



Liuk
Barovier&Toso 2013

Lust
Marcel Wanders 2015









Perseus
Marcel Wanders 2015





















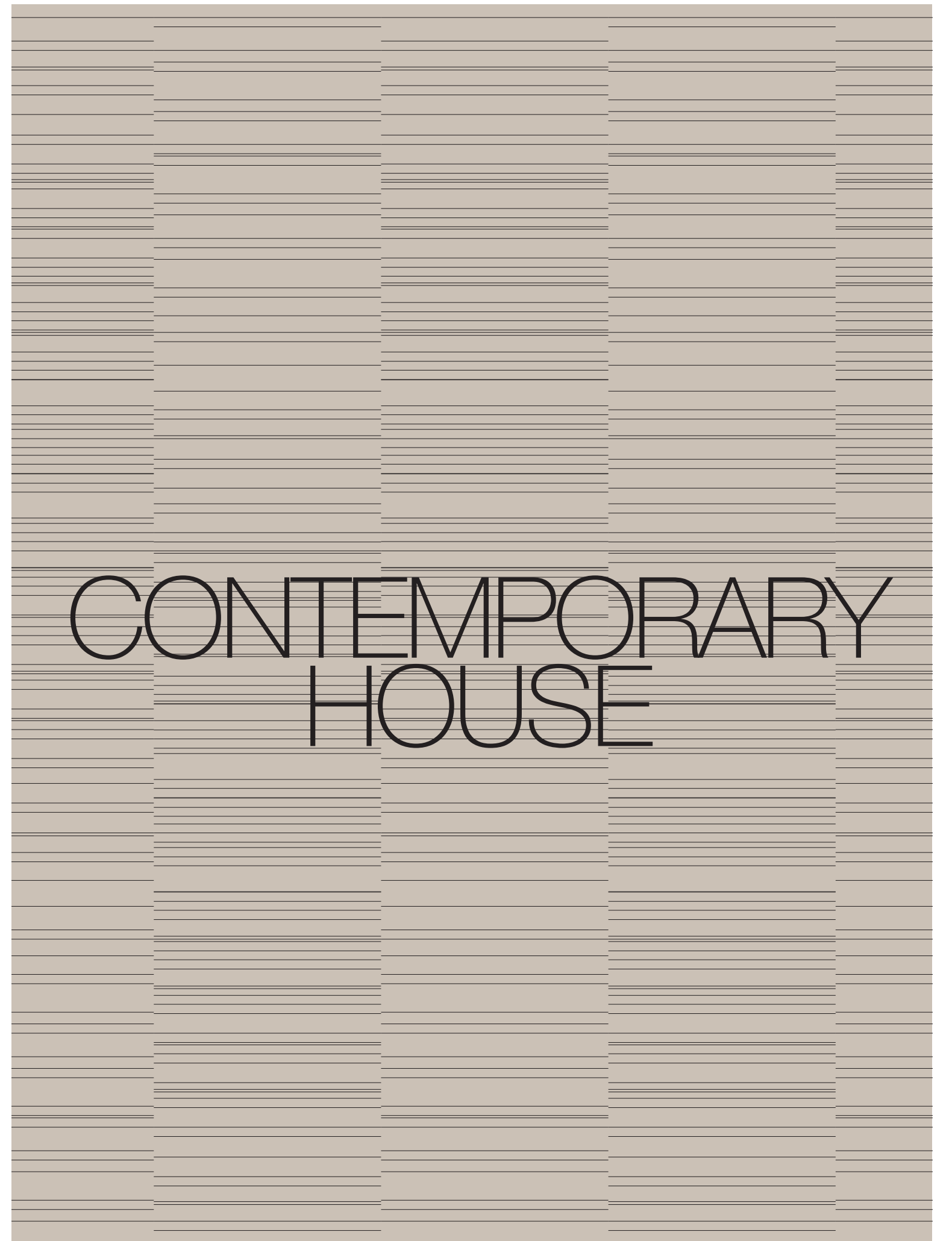
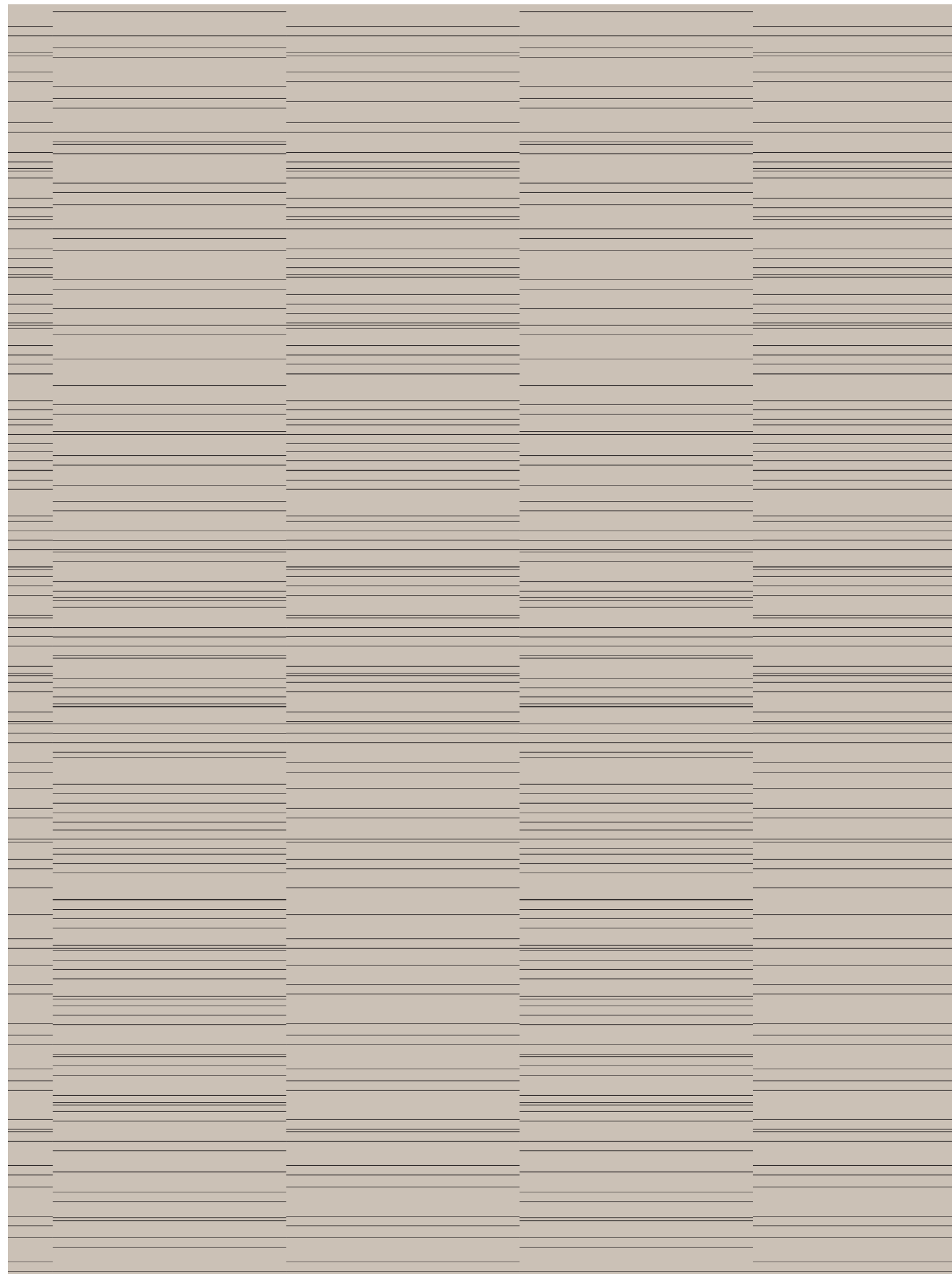





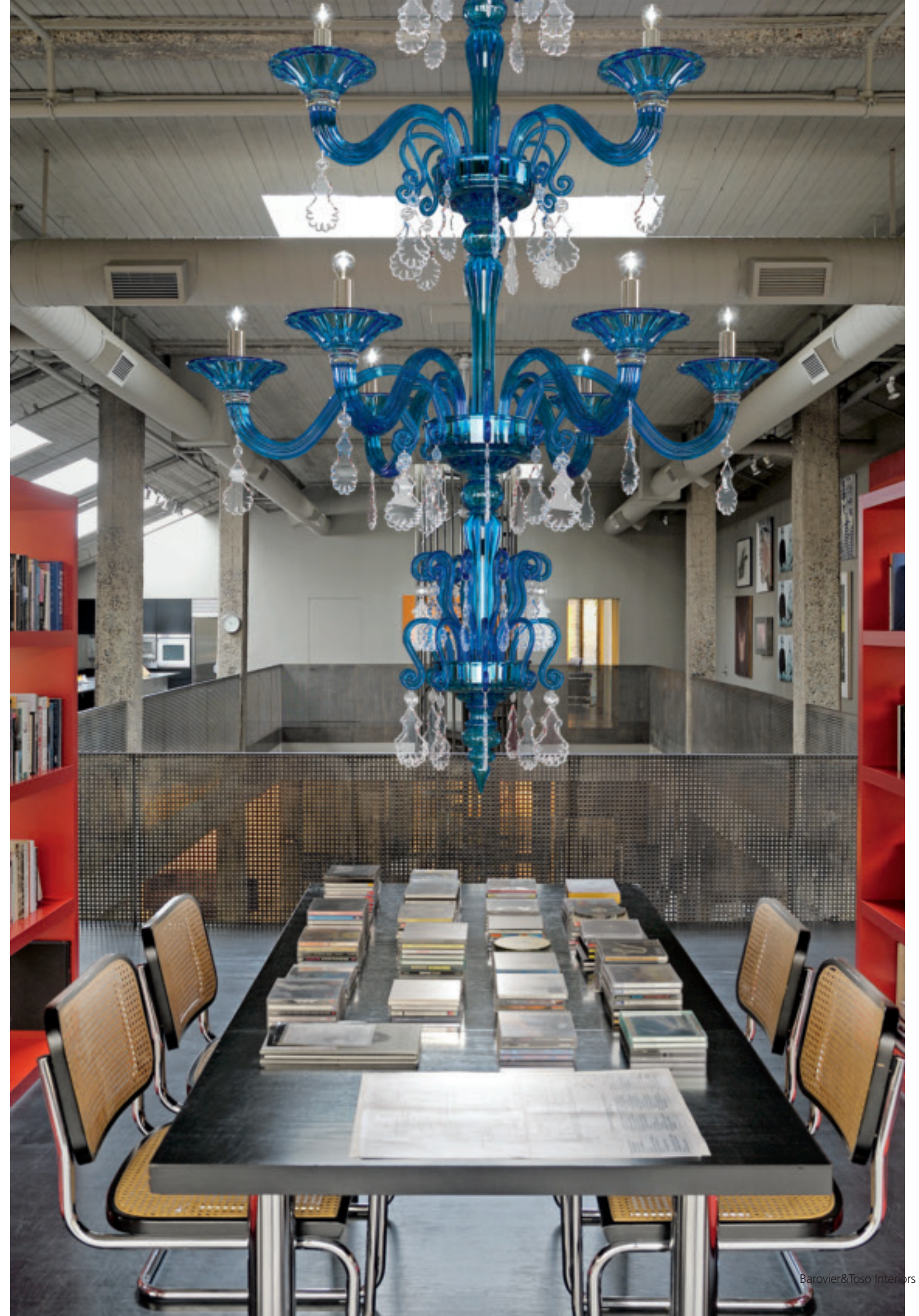











Palmyra
Fabio Calvi Paolo Brambilla 2015















Matrioska
Barovier&Toso 2009



Torpedo Amsterdam
Barovier&Toso 2010







Optical
Barovier&Toso 2007









Bissa Boba
Angelo Barovier 1992/2004











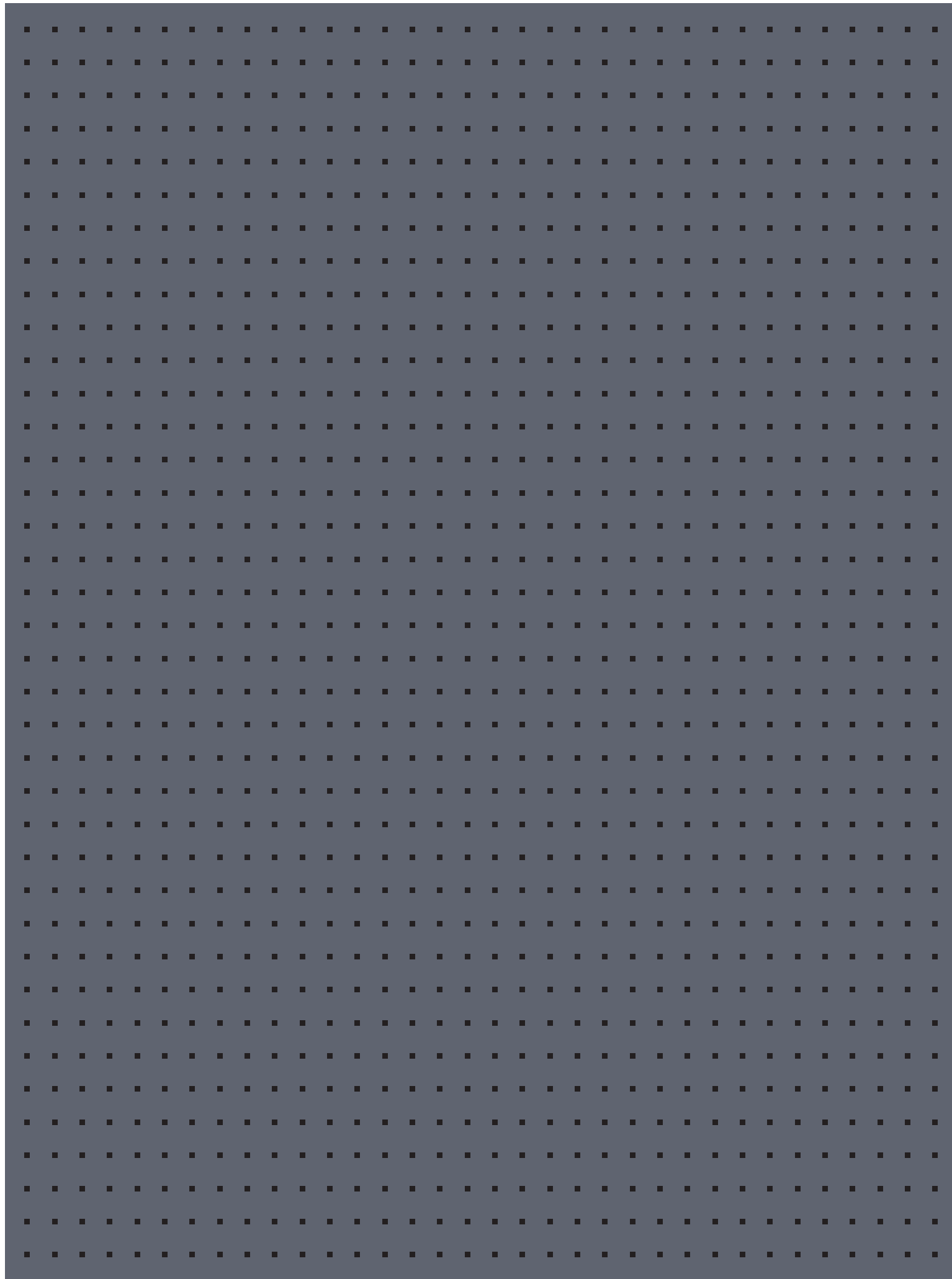

















References

Izmir
pag 42-43, 148-149

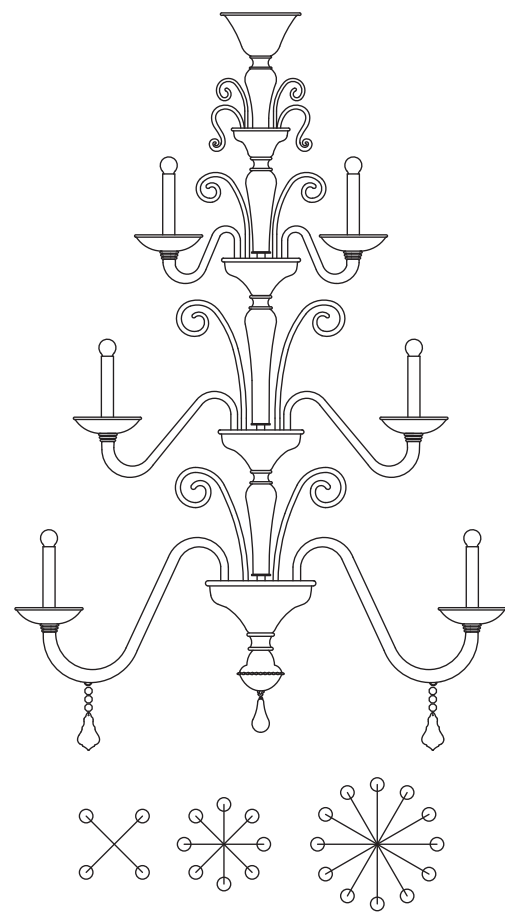

Taif
pag 12-13, 36-37, 122-125

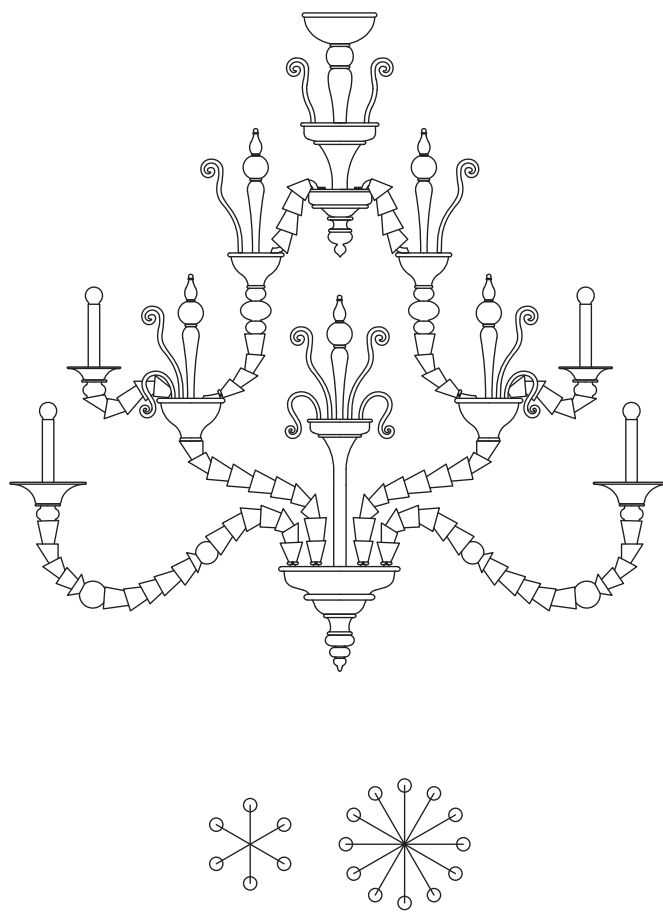

Windsor
pag 112-113

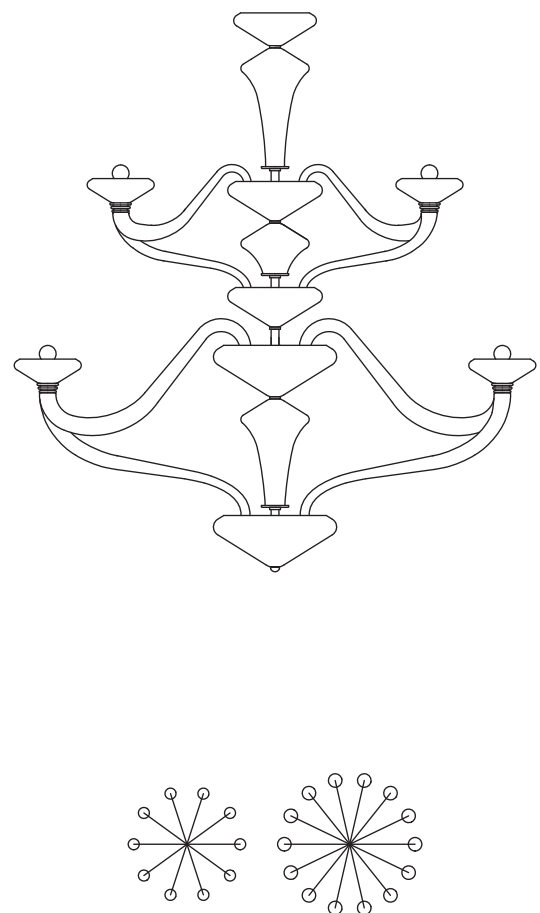

Bissa Boba
pag 141-143

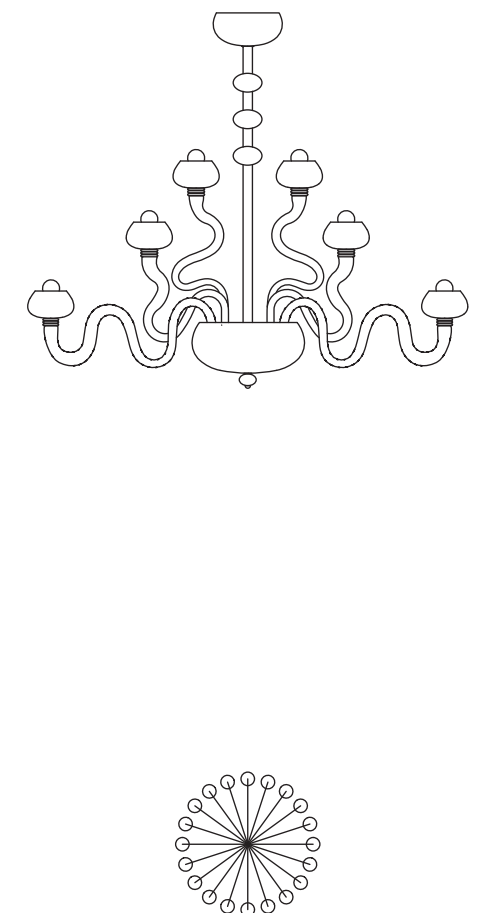

Tangeri
pag 34-35, 63

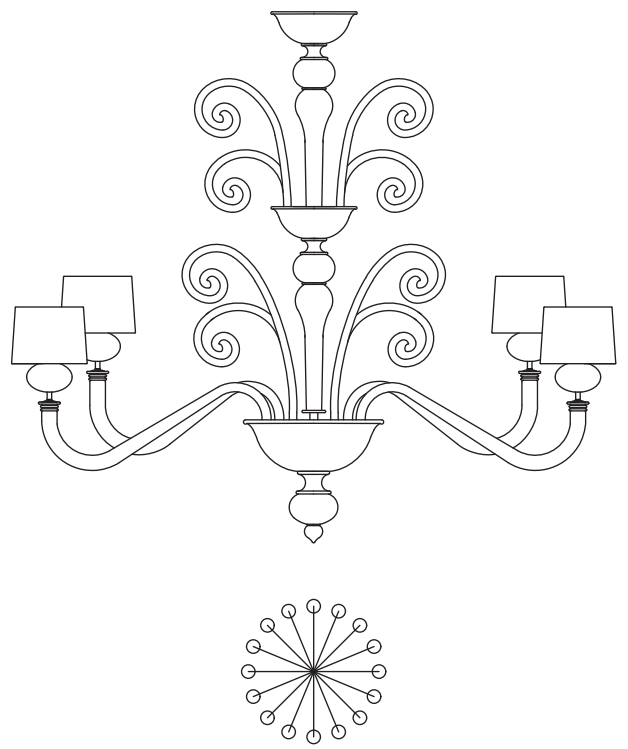

Fauve
pag 56-59

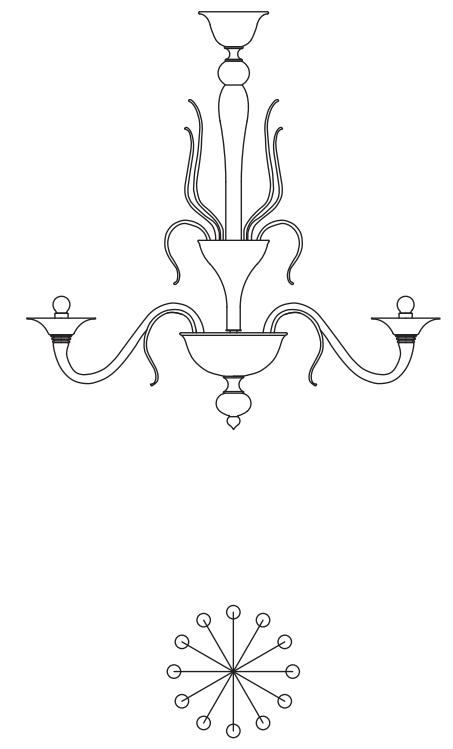

Saint Germain
pag 14-15

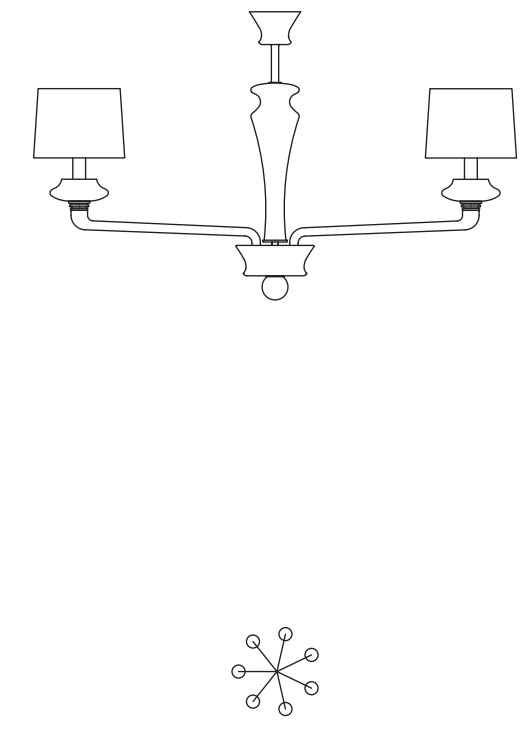

Palladiano
pag 144-147

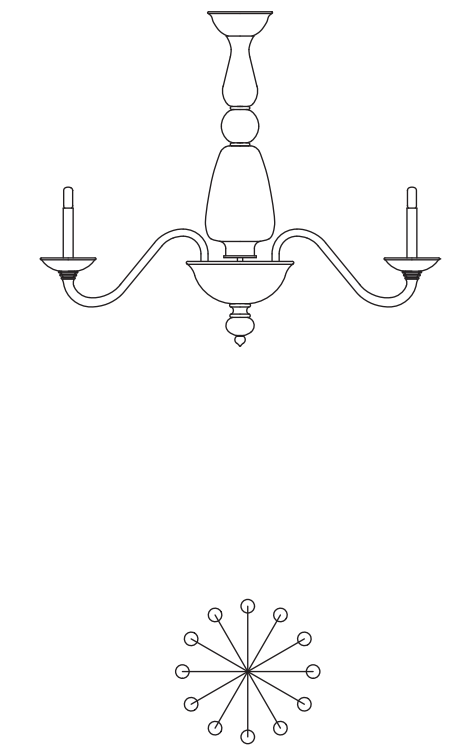

Rotterdam
pag 94-96

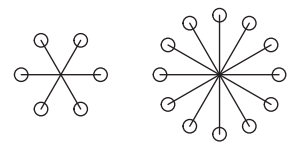
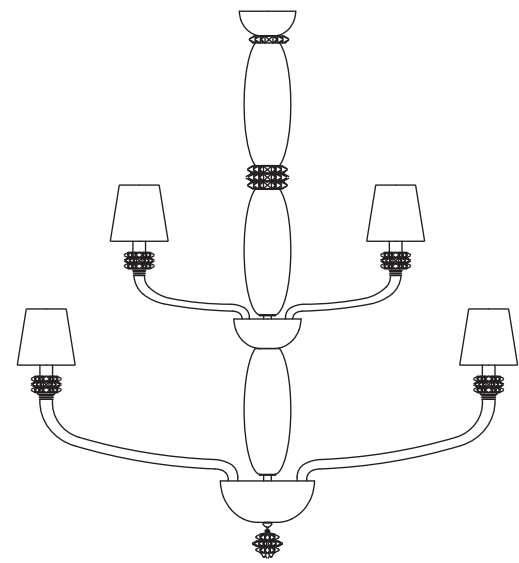

Maine
pag 20-23

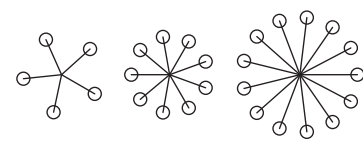
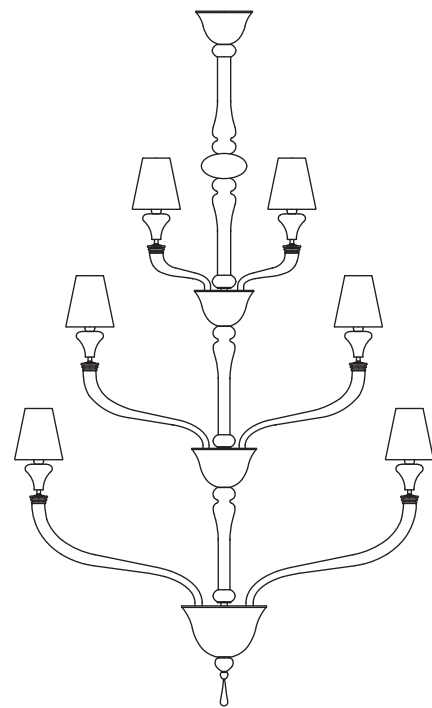

Torpedo Taif
pag 104-107

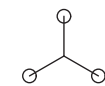
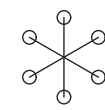
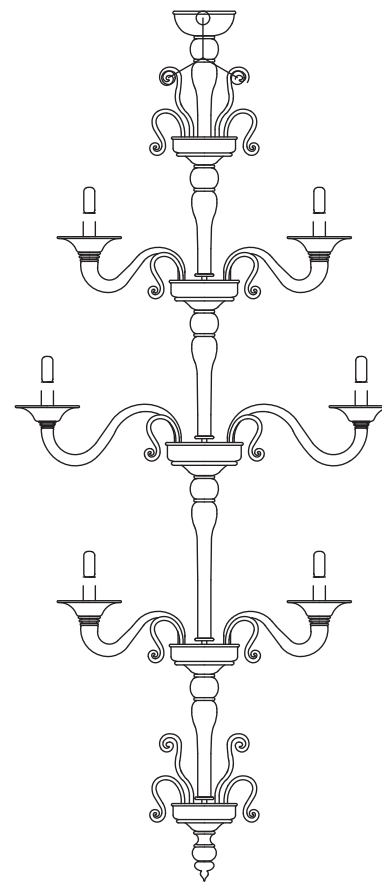

Torpedo Amsterdam
pag 24-27, 130-131

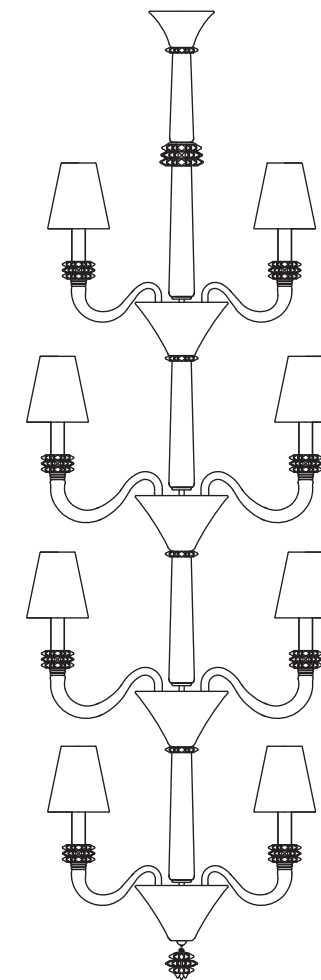

Colimaçon
pag 97

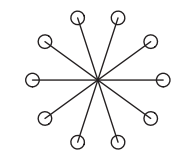
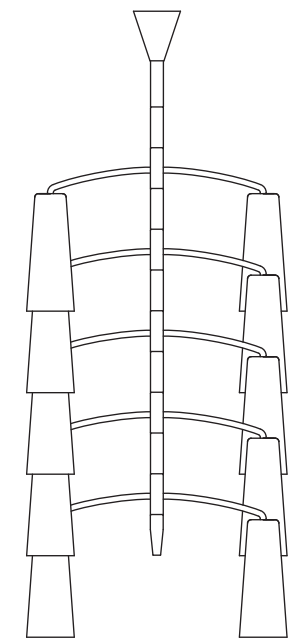

Alexandria
pag 28-29

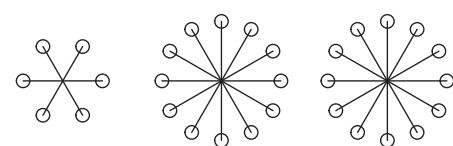
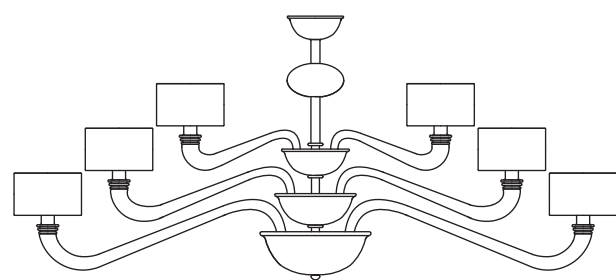

Nevada
pag 87-89

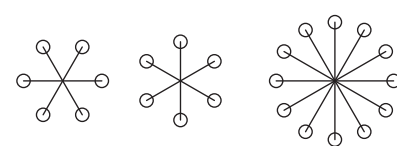
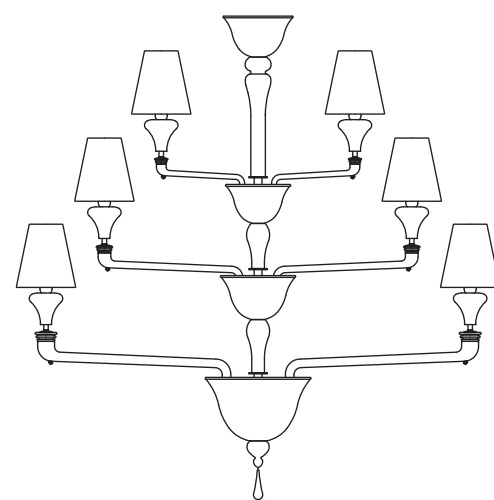

Colimaçon
pag 132-133

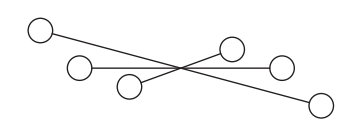
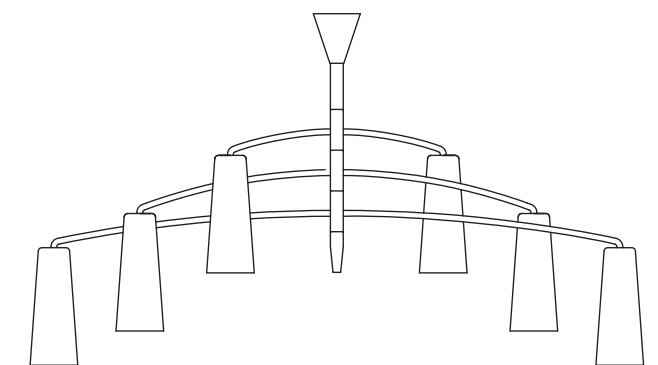

Ran Front
pag 49-51

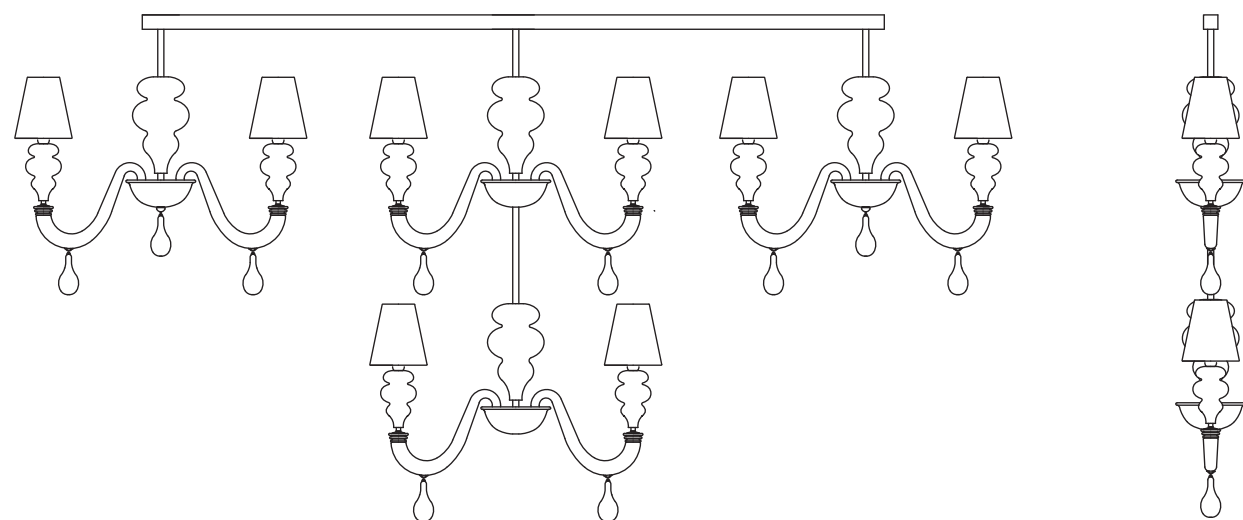

Matrioska
pag 126-129

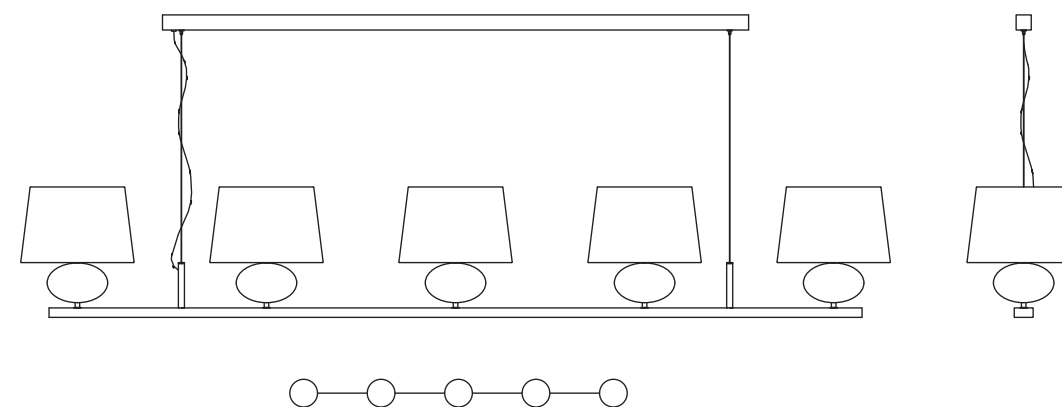

Domo Nevada
pag 136-139

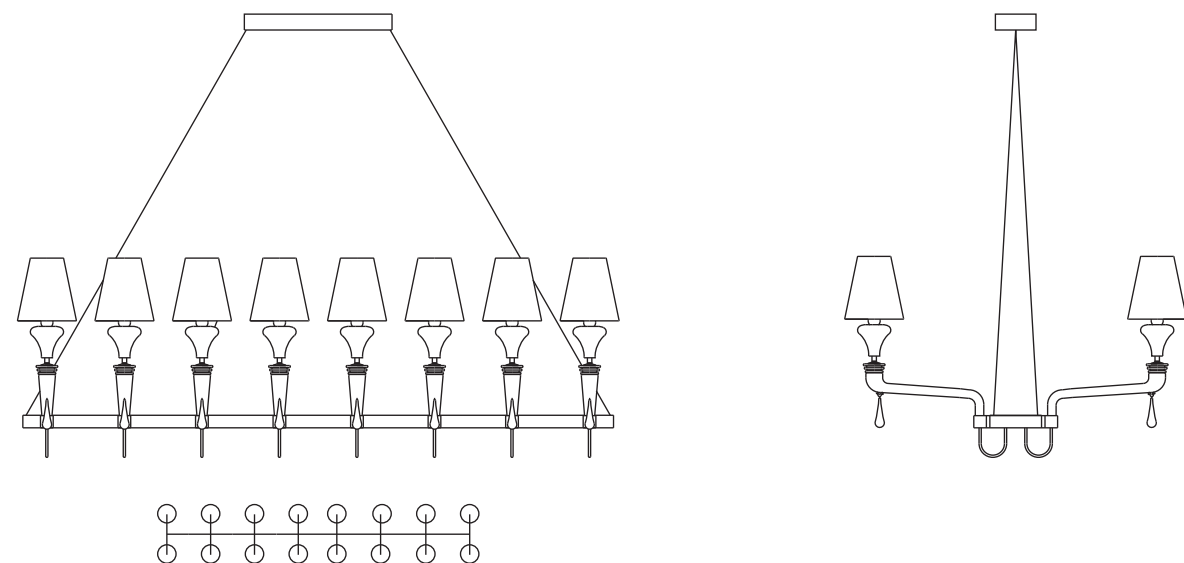

Twins
pag 108-110

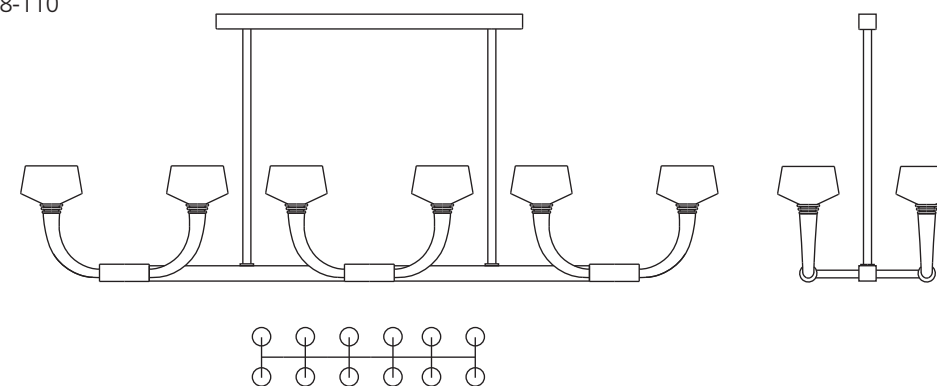

Mood Taymyr
pag 91-93

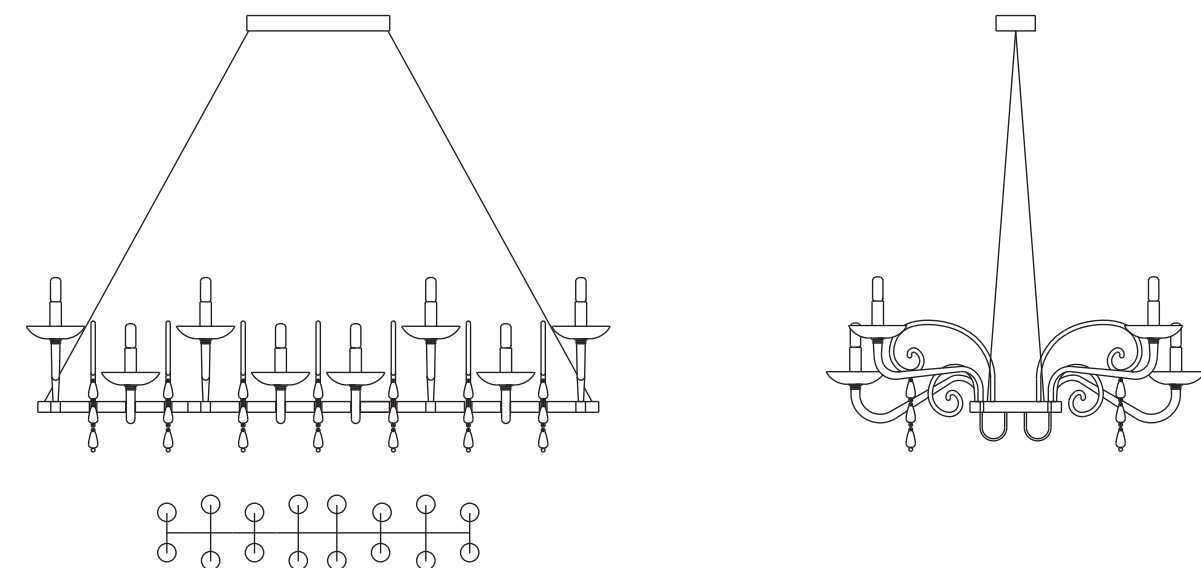

Shadow Taif
pag 39-41, 64-65

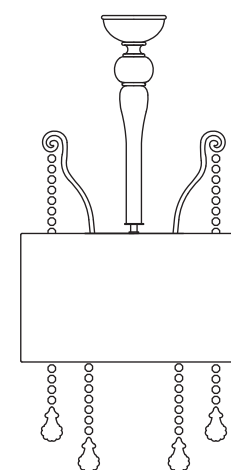

Pandora
pag 16-17

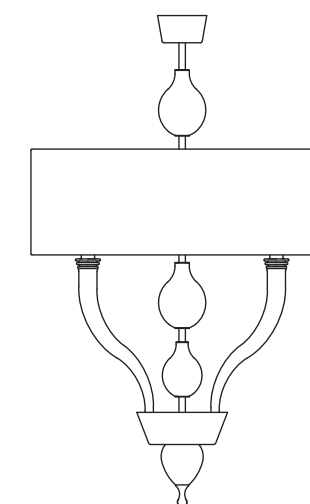

Optical
pag 44-47, 134-135

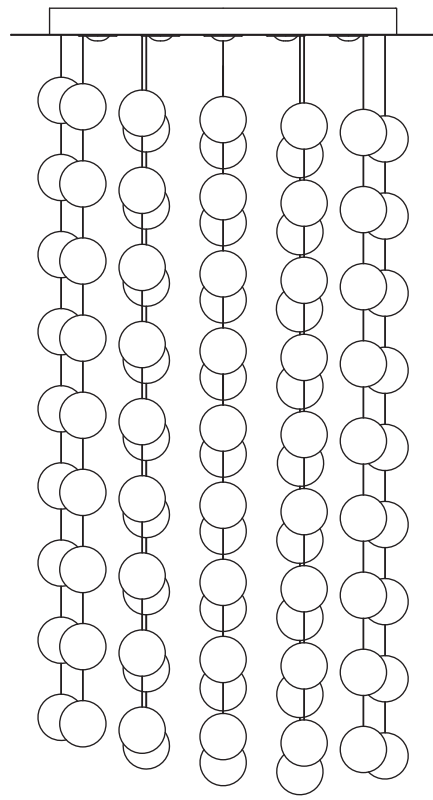

Mazzodromo
pag 76-79

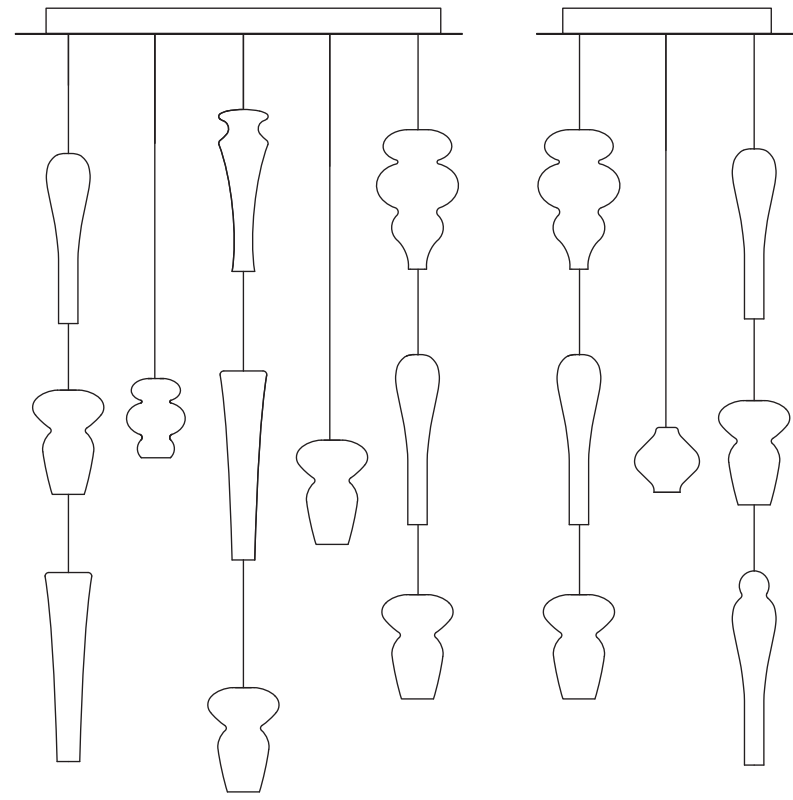

Hanami
pag 114-115

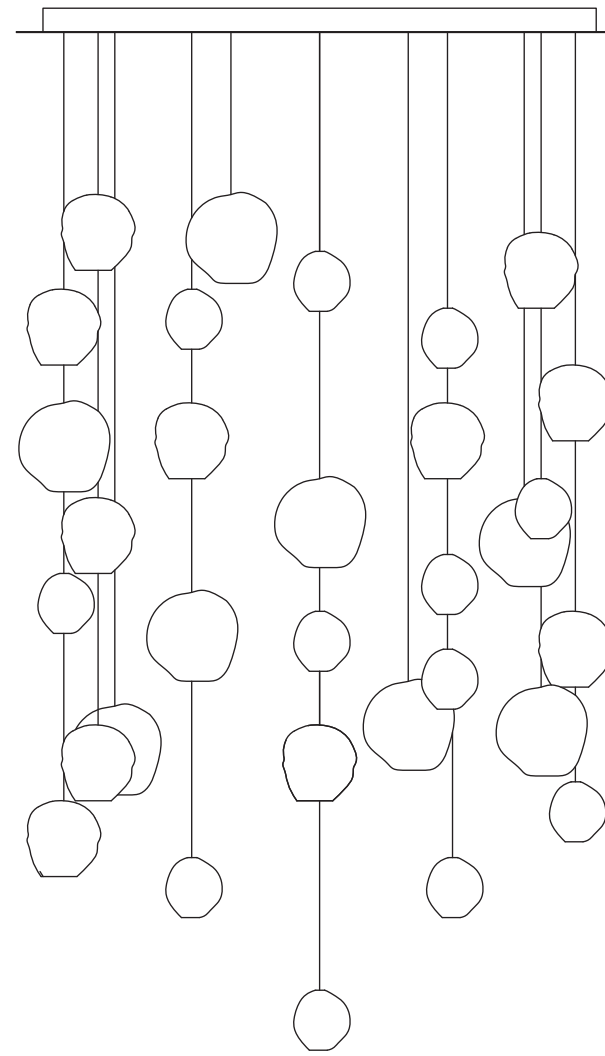

Spinn
pag 152-155

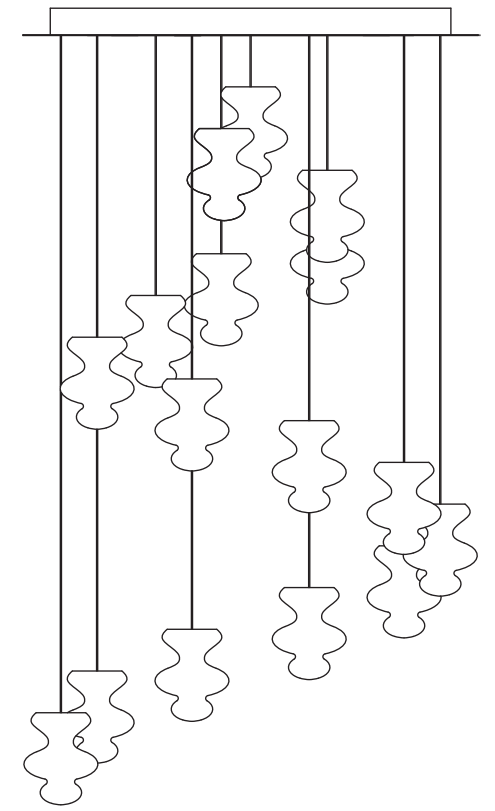

Manhattan
pag 30-32

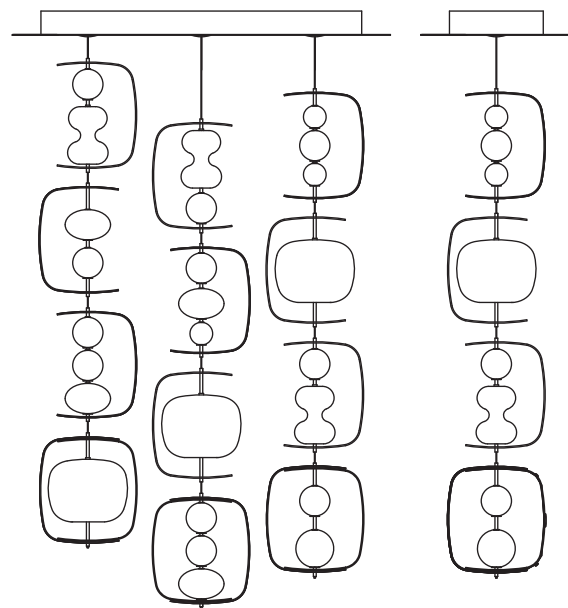

Exagon
pag 52-55, 98-99

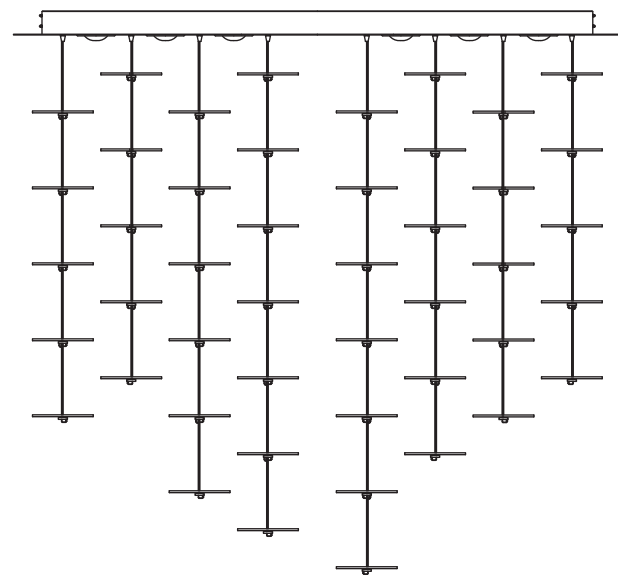

Liuk
pag 72-75

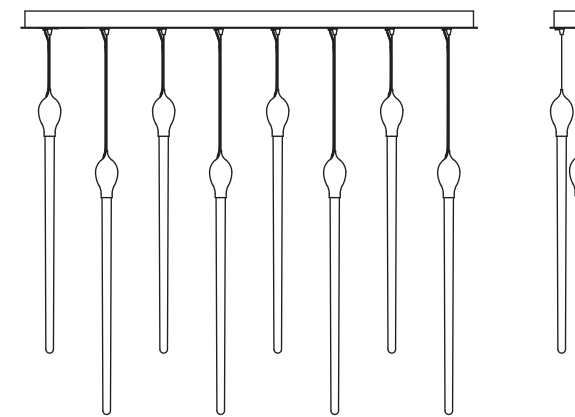

Cechi
pag 68-70

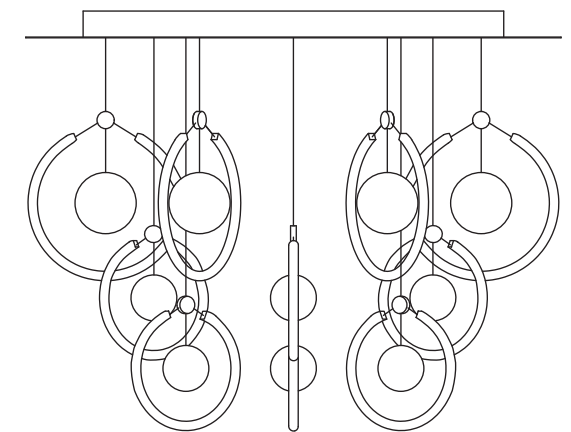

Escher
pag 118-121

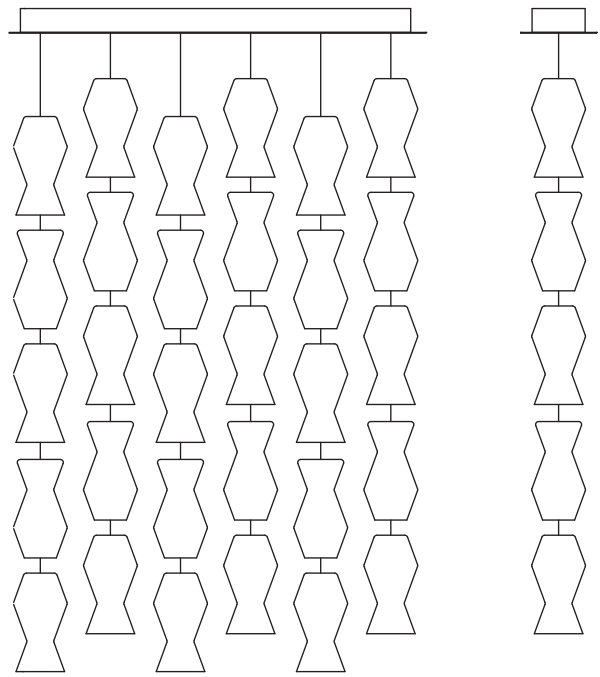

Palmyra
pag 116-117, 164-165

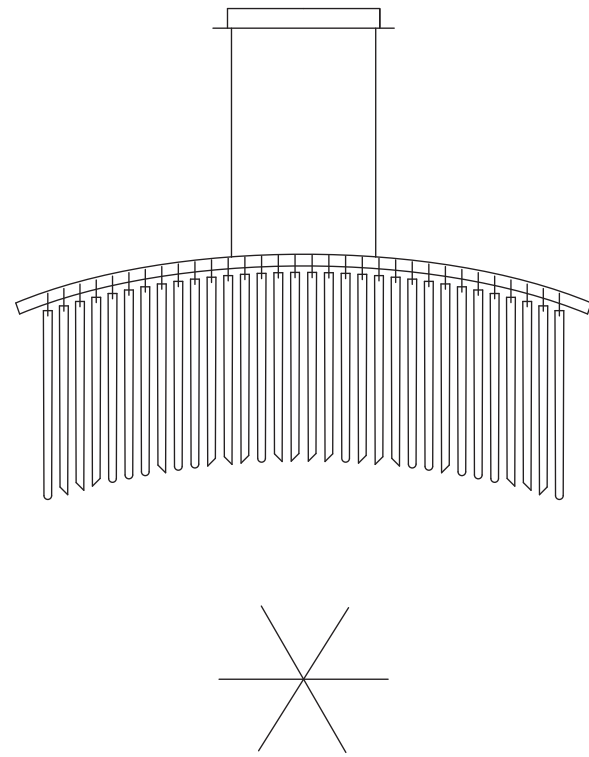

Lincoln
pag 162-163

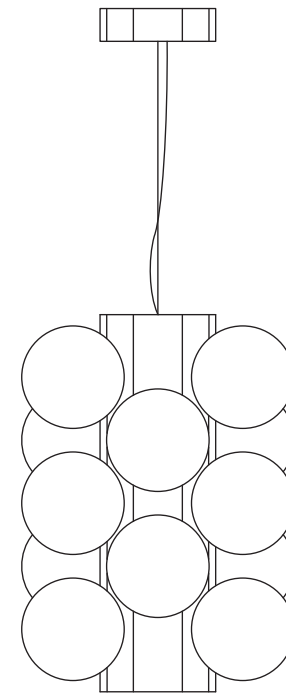

Hastings
pag 157-159

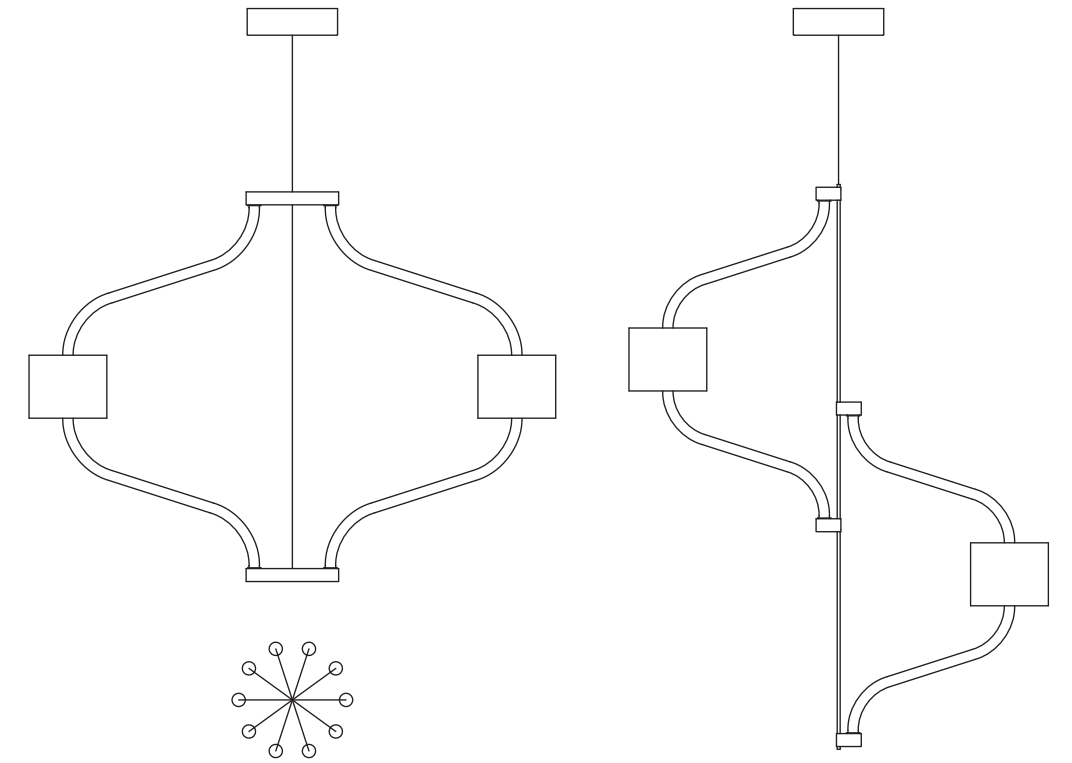

Perseus
pag 18-19, 80-81, 166-167

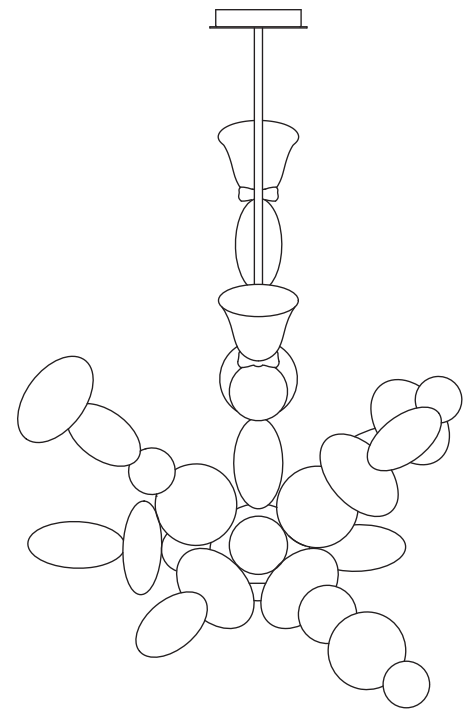

Angel
pag 8-10

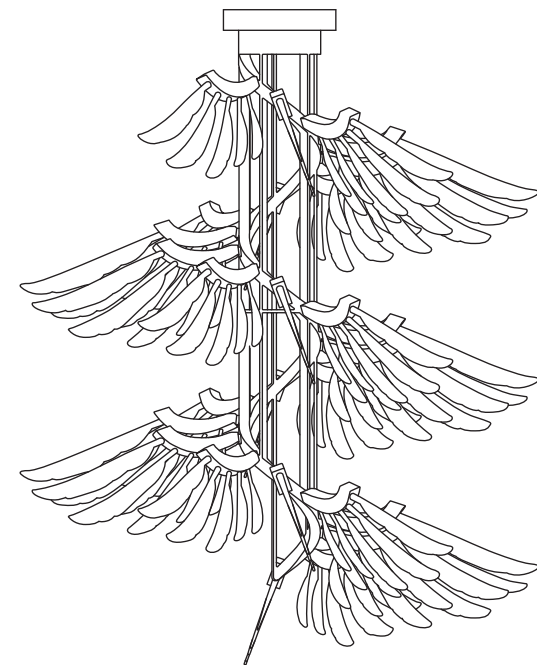

Lincoln
pag 160-161

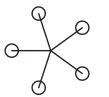
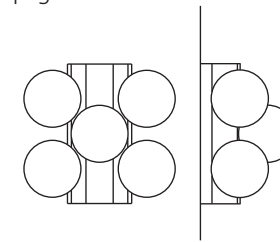

Samurai
pag 60-61

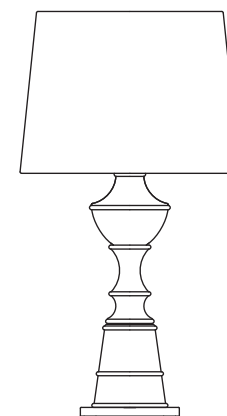

Saint Germain
pag 14-15

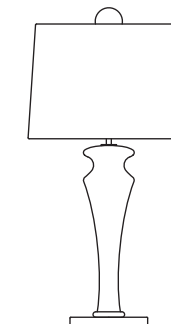

Lust
pag 18-19, 72-75



Pigalle
pag 102-103

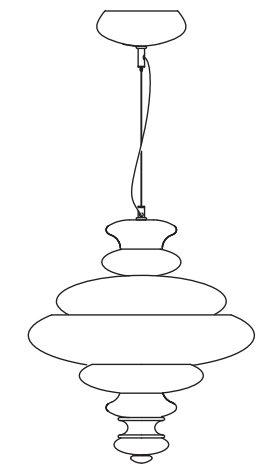

Robin
pag 83-85

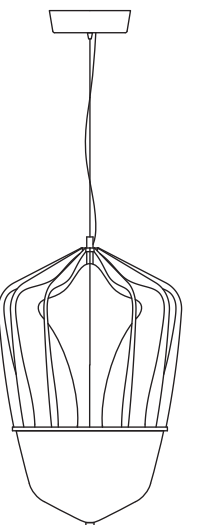

Concept and graphic

Marco Strina

Photo editor

Nataschia Vuk

Project manager

Massimo Bovi

Photo credit

Filippo Bamberghi 20,21,114,115

Gianni Basso / Vega MG 22,23,98,99, 157,158,159,166,167

Denise Bonenti / Vega MG 28,29

Franco Chimenti 42,43,56,57,58,59,144,145,146,147

Gianni Franchellucci / Living Inside 8,9,10,12,13,14,15,16,17,18,19,68,69,70,76,77,78,79,83,84,85,104,105,107,108,109,110,116,117,118,119,120,121

Chris Gascogne / VIEW 160,161

Gaelle Le Boulicat 30,31,32,44,46,47,49,50,51,72,73,74,75,80,81,87,88,89,112,113,130,131,132,133,134,135,136,137,138,139

Davide Lovatti / Vega MG 91,92,93,94,95,96,97

Lorenzo Nencioni / Vega MG 39,40,41,140,141,142,143

James Newton / VIEW 164,165

Eugeni Pons / Vega MG 122,123,124,125,126,127,128,129

Giorgio Possenti / Vega MG 148,149

National Trust 162,163

Ego 24,25,26,27,34,35,52,53,54,55,60,61,63,64,65

Turri 152,153,154,155

Compositing 3D

Reality Studio, Modena - www.realitystudio.it

8,9,10,12,13,14,15,16,17,18,19,20,21,24,25,26,27,28,29,44,46,47,49,50,51,60,61,68,69,70,72,73,74,75,76,77,78,79,80,81,83,84,85,87,88,89,91,92,93,94,95,96,97,102,103,104,105,107,112,113,114,115,116,117,118,119,120,121,130,131,132,133,134,135,136,137,138,139,141,142,143,152,153,154,155,157,158,159,160,161,162,163,164,165,166,167

Bluemotion, Padova - www.bluemotion.it

30,31,32,34,35,36,37,39,40,41,42,43,52,53,54,55,56,57,58,59,63,64,65,98,99,122,123,124,125,126,127,128,129,144,145,146,147,148,149

Press Office

EVDS - Elisa Velluto, Daniela Sarracco

Prepress

UPstudio

Print

ciesse printer - Padova - april 2016

Thanks to

Ego - www.egozeroventiquattro.it

Turri - www.turri.it

Barovier&Toso

Vetriere Artistiche Riunite srl

Fondamenta Vetrai 28

30141 Murano

Venezia

T +39 041739049

F +39 0415274385

barovier@barovier.com

www.barovier.com

Showroom

Milano - Via Durini 5

Murano - Fondamenta Vetrai 28

